

Project: I – S.K.Y.P.E. (Interactive Science for Kids and Youngsters in Primary Education)

This project has been funded with the support of the Erasmus+ Programme, K2 Action, Strategic Partnerships in School Education.

Project Agreement Number: 2016-1-SK01-KA201-022549

I-S.K.Y.P.E.

Interactive Science for Kids and Youngsters in Primary Education

Workshop for Teachers

The current publication reflects only the author's view and neither the Slovak National Agency, nor the European Commission are responsible for any use that may be made of the information it contains.

Content

1. Teaching science for understanding

- Main Idea: Why teaching science? What science should we teach?
- Big Ideas of Science
- How to develop Big Ideas

2. Model of learning through inquiry (Wynne Harlen)

3. Science process skills

4. Examples of activities

Content

1. Teaching science for understanding

- Main Idea: Why teaching science? What science should we teach?
- Big Ideas of Science
- How to develop Big Ideas

2. Model of learning through inquiry (Wynne Harlen)

3. Science process skills

4. Examples of activities

Main Idea: Why teaching science? What science should we teach?

Education should not only generate knowledge, but also prepare the students for life. Thus it has to develop children's natural way of thinking, based on rational reasoning, because the product of the thinking process is used for understanding what happens in the world around them.

But this is contrary to the science education in schools nowadays. Students complain about memorizing facts and formulas and teachers still feel the absence of confidence in teaching science related subjects because of the lack of resources and ideas on how to motivate learners, as well as specifics of the curriculum and syllabus of these subjects.

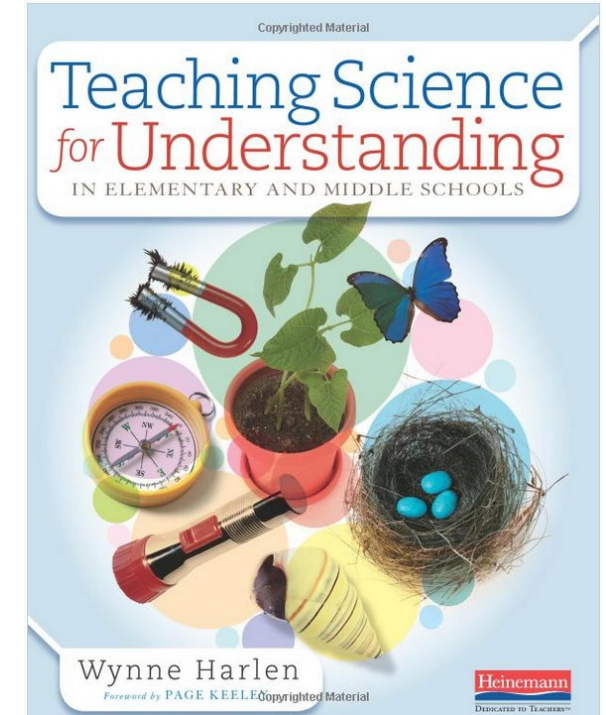

Main Idea: Why teaching science? What science should we teach?

Scientific knowledge:
concepts, theories etc.



Scientific process skills: raising
questions, observation, collecting
data etc.

While thinking about suitable educational instructions for primary science education, it is important to realize, that natural sciences are specific not only by its content (**scientific knowledge**), but also by the process of how the scientific knowledge is created (**scientific process skills**)!

What do you think?: What skills and competencies should students acquire in science education?



Science Education – Skills and competencies

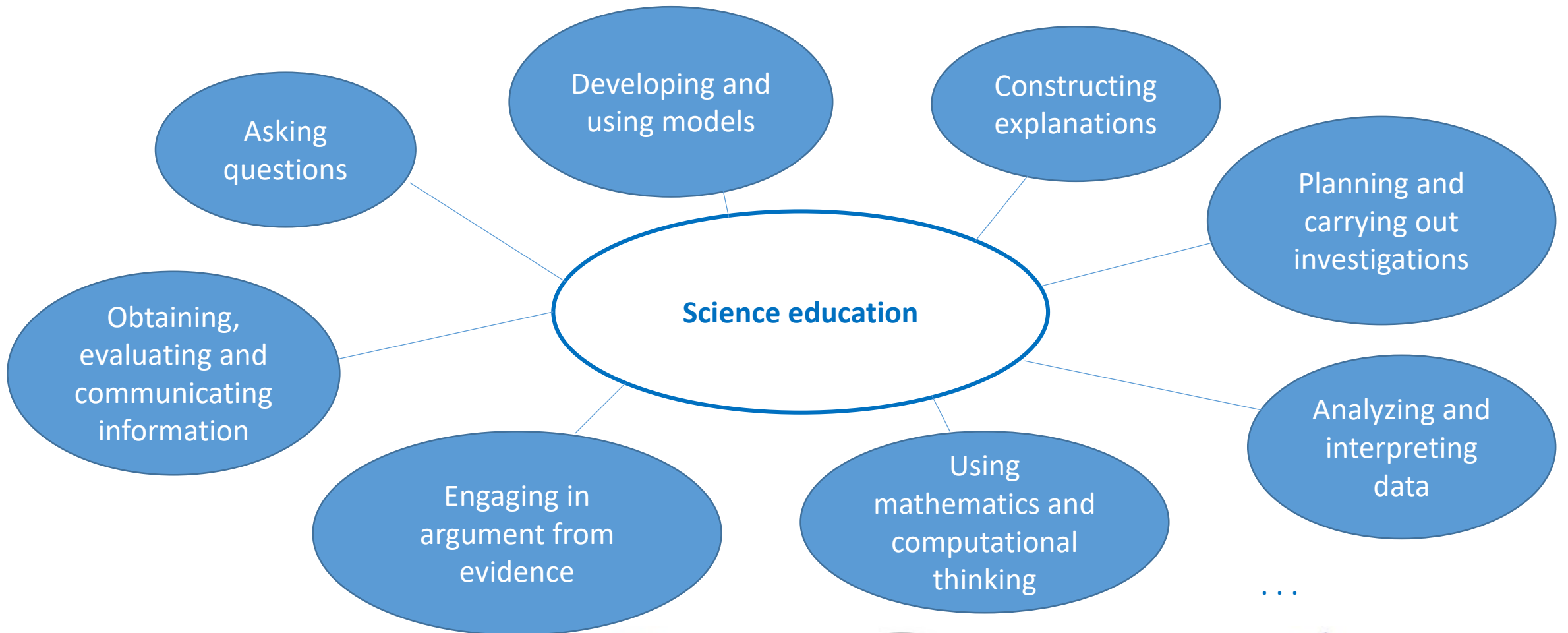

Main idea: Why teaching science? What science should we teach?

Accordingly, there are some important features to consider regarding effective science teaching:

- **Experiences and interests of the students are focused:**

The teacher has to introduce assignments etc. that are founded by the interests of the students. Then they are engaged and motivated to answer the questions and problems they have raised through researching. Thus the teacher enables them to develop ideas and skills based on their experiences and topics.

- **Attitude:**

The interests of the students should be perceived and taken seriously. Furthermore it is important, that the teacher knows the students very well, because then he/she can take into account their stage of development, plan the lessons according to their competencies and give the right assistance (scaffolding). In addition, it is important which attitude the teacher himself or herself has to science. He must have the confidence to teach science related subjects and notice the importance of science knowledge and process skills for the overall development of the students.

Main idea: Why teaching science? What science should we teach?

- **Developing a climate of learning:**

The activities happening in the classroom take place within the social climate. The teacher and the other adults have an important role helping students to create their knowledge, because they influence each other in their ability and willingness to learn. It is important that they respect each other and the different ideas and interests are valued and taken seriously. Thus a classroom climate in which the students feel safe to express their ideas could be established and lays the foundation for continued and motivated learning.

Content

1. Teaching science for understanding

- Main Idea: Why teaching science? What science should we teach?
- [Big Ideas of Science](#)
- How to develop Big Ideas

2. Model of learning through inquiry (Wynne Harlen)

3. Science process skills

4. Examples of activities

Main idea: Which concept suits best with these considerations?

A very suitable concept we can use for appropriate development of scientific literacy is the concept of **Big Ideas in Science Education** (Prof. Wynne Harlen, University Bristol), because it clearly reflects most of the actual problems of primary science education. It is aimed not only on functional development of fundamental ideas of science, but it deals also with scientific processes and the whole nature of science. The scientific content is developed together with the scientific process skills using inductive way of teaching. Overall the students obtain an appropriate idea about the nature of science.



Main idea: Which concept suits best with these considerations?

The concept identifies **14 ideas** to be developed during elementary science education: **10 fundamental Big Ideas of Science** and additional **4 Big Ideas about Science**.

The ideas are...

... so big that they explain many different phenomena.

... still so comprehensible that even elementary school students can approach them.

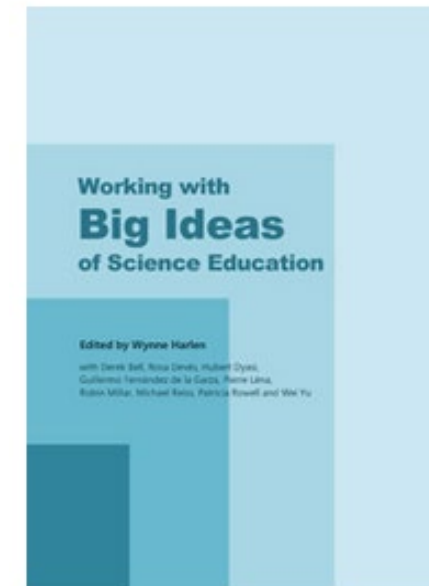

Note: In contrast isolated facts do not contribute extensive scientific knowledge!

Big Ideas of Science Education according to Wynne Harlen 1

- 1. All matter in the universe is made of very small particles**
Atoms are the building blocks of all matter, living and non-living.
- 2. Objects can effect other objects at a distance**
Radiation (e.g. visible light), magnetic, electric or gravitational field.
- 3. Changing the movement of an object requires a net force to be acting on it**
A force acting on an object is not seen directly but is detected by its effect on the object's motion or shape. If an object is not moving the forces acting on it are equal in size and opposite.
- 4. The total amount of energy in the universe is always the same but can be transferred from one energy store to another during an event**
Energy can be transferred from one body or group of bodies to another in various ways.

Big Ideas of Science Education according to Wynne Harlen 2

5. **The composition of the earth and its atmosphere and the processes occurring within them shape the earth's surface and its climate**
Volcanoes and earthquakes, movement of the plates which form the earth's crust, solar radiation, climate
6. **Our solar system is a very small part of one of billions of galaxies in the universe**
Day and night and the seasons are explained by the orientation and rotation of the earth as it moves round the sun.
7. **Organisms are organized on a cellular basis and have finite life span**
Organisms with one or more cells, multi-cellular organisms with different cells according to their function, growth is the result of multiple cell divisions
8. **Organisms require a supply of energy and materials for which they often depend on, or compete with, other organisms**
Food provides materials and energy to carry out the basic functions of life and to grow.

Big Ideas of Science Education according to Wynne Harlen 3

9. **Genetic information is passed down from one generation of organisms to another**
DNA, asexual and sexual reproduction, genes determine the development and structure of organisms

10. **The diversity of organisms, living and extinct, is the result of evolution**
universal common ancestor, changes and selection, extinction of species

Big Ideas about Science according to Wynne Harlen

1. Science is about finding the cause or cause of phenomena in the natural world

The diversity of natural phenomena requires a diversity of methods and instruments to generate and test scientific explanations.

2. Scientific explanations, theories and models are those that best fit the evidence available at a particular time

A scientific theory or model representing relationships between variables of a natural phenomenon must fit the observations available at the time and lead to predictions that can be tested.

3. The knowledge produced by science is used in engineering and technologies to create products to serve human ends

The use of scientific ideas in technologies has made changes in many aspects of human activity. Advances in technologies enable further scientific activity; in turn this increases understanding of the natural world.

4. Applications of science often have ethical, social, economic and political implications

Ethical and moral judgments may be needed, based on such consideration as justice or equity, human safety and impacts on people and the environment.

Content

1. Teaching science for understanding

- Main Idea: Why teaching science? What science should we teach?
- Big Ideas of Science
- [How to develop Big Ideas](#)

2. Model of learning through inquiry (Wynne Harlen)

3. Science process skills

4. Examples of activities

How to develop Big Ideas: from small to big ideas

The life of the students is full of experiences which can not be explained by their previous knowledge. Their thinking and their scientific understanding are still evolving. Typically students are keen on understanding phenomena, but are not yet able to grasp all the necessary perspectives and to consider them in their deliberations or to understand different relationships and interactions between individual phenomena.

Therefore, it is necessary for students to observe and study these phenomena continuously and in-depth. Thus they are able to understand the mutual aspects of them and the small ideas (which are explaining particle phenomena) are further linked together using induction – from small the bigger ideas are created.

This bigger idea is more functional and helps to understand natural phenomena better. Therefore students should be equipped with a huge amount of small ideas, because they are essential for the creation of ideas which are more operational and general.

How to develop Big Ideas: from small to big ideas

This process in which small ideas are shifted to bigger ones could be compared to the process of solving a puzzle. The small pieces have to be observed and examined to look how they fit together. Thus with the small particular pieces (for example with the same color) a bigger one could be created which in turn is a small part of the whole picture. Therefore it is necessary to observe and compare a lot for creating the small parts of the puzzle.



Borders of the small parts indicate how they are going to be put together – if we observe them well.

So it is similar to the process using induction, because the small ideas are put together to create a complex picture of the whole phenomenon.

How to develop Big Ideas: from small to big ideas

The special thing about this concept is, that the big idea is always present. It sets the framework and the structure in which the students could move and examine the whole phenomenon. Thus it is important that the teacher always have the big idea in mind, because he or she has to guide the students if they run out of the frame but also has to encourage them to move within the framework for improving their knowledge and skills by learning through inquiry.



How to develop Big Ideas: from scientific content-related ideas to scientific process-related ideas

The entire process is raised by some experience the student makes in interacting with his environment, creating questions or problems which need to be answered. Thus the starting point of every activity is in proposition of an appropriate research (inquiry) question. To find an answer, these content-related questions must be transferred in process-related questions, because then the problem can be examined by learning through inquiry.

The role of the teacher is, to lead the students to find the answer, using inquiry and introduction as a part of it. All the proposed teaching instructions should lead the students to their inquiry effort. Using this approach, science process skills can be developed.

The students feel their own competence to find answers and further they are more willing to deal with more and more difficult tasks. Development of science process skills equips students with a tool for changing small ideas to bigger ones, because they are moving from description to understanding the nature.

How to develop Big Ideas: grasping nature of science using inductive way of teaching

The cognitive key tool the students use to develop their ideas of and about science can be named as scientific skill and could further described as follows: scientific capability concerned with gathering and using evidence for proving or refuting prior understanding. This complex skill can be split into specific skills and further can be better understood in connection with effort of scientific literacy development. The activities proposed in the I-S.K.Y.P.E. project are designed to highlight development of the mentioned skills.

Content

1. Teaching science for understanding

- Main Idea: Why teaching science? What science should we teach?
- Big Ideas of Science
- How to develop Big Ideas

2. Model of learning through inquiry (Wynne Harlen)

3. Science process skills

4. Examples of activities

Model of learning through inquiry

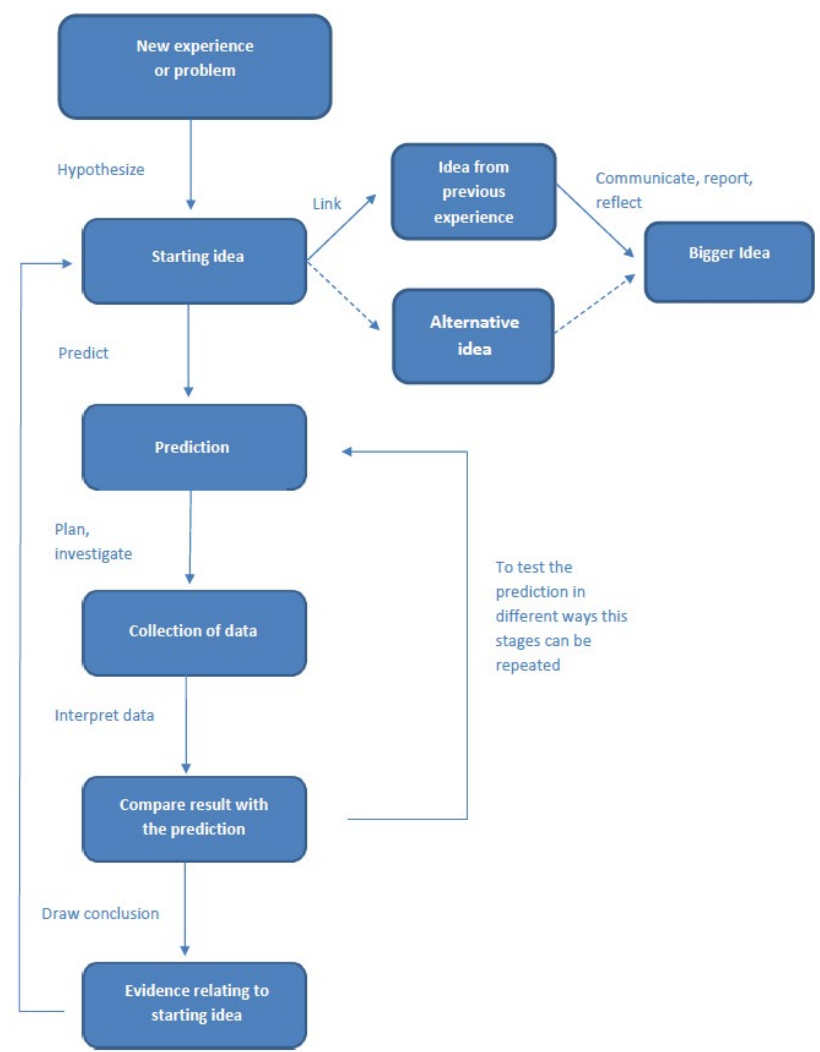

Model of learning through inquiry: general information

The theoretical basis of the concept of the big ideas is, that the students should learn through inquiry. That means they shouldn't only create knowledge by memorizing facts and by mere describing *what* they see. They should understand the underlying mechanisms also. The aim is that students understand *why* objects have certain characteristics and show certain behaviours (e.g. float or fly).

To find out about the „*why*“, the underlying mechanisms, students need several (science process) skills, like hypothesizing, planning, observing, which organise the process of learning through inquiry. The term inquiry itself refers to seeking information to answer questions which is the general part of scientific research. Thus scientific inquiry applies to questions of the (natural and made) world around us and leads to the understanding of scientific phenomena.

The model of learning through inquiry pictured the individual steps of a scientific research process. It can be adapted to the level of development of the students, so you don't have to start from the beginning, but could start at the point in the research process where the students are currently standing.

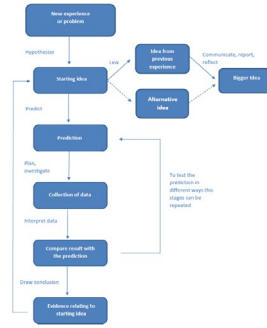

Model of learning through inquiry: general information

“Developing scientific inquiry skills is central to the construction of ideas that enable understanding. This is an important reason for helping students develop their inquiry skills and use them with appropriate rigor. Another reason, of course, is that by reflecting on their learning they develop skills needed for making sense of new experiences throughout their lives.” (Harlen, 2015)

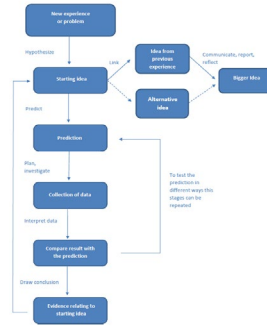

To illustrate the process of scientific research, the individual steps of the model of learning through inquiry are described subsequent.

Model of learning through inquiry: Stages

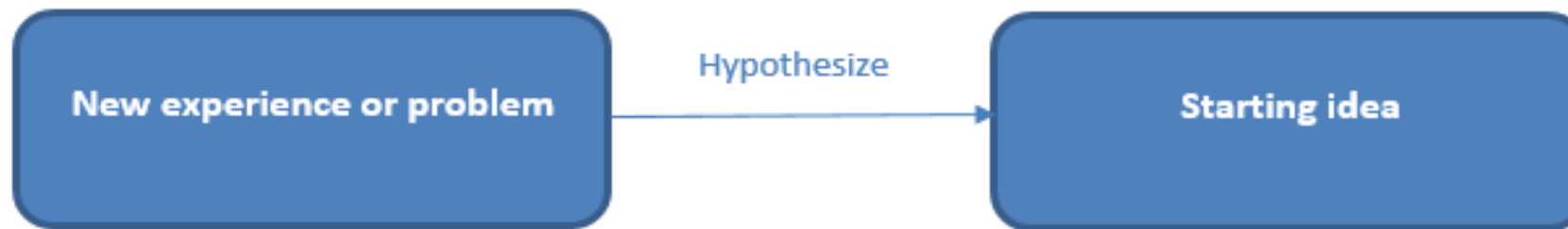

The process starts with a new experience or a problem that raises a question, because it couldn't be explained with the current knowledge of the students. Thus the experience or the problem has to be compared with the own experiences to identify investigable questions and hypotheses. Hence a starting idea, which forms the basis of the scientific research process, has been created.

Model of learning through inquiry: Stages

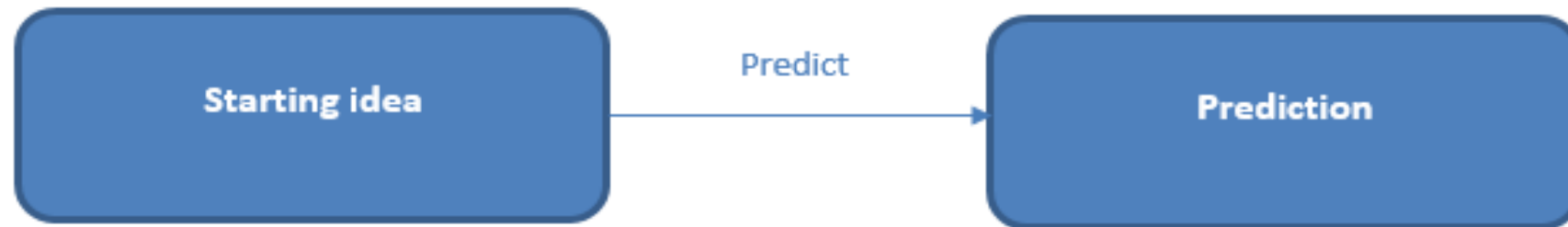

Within the starting idea there are several hypotheses to be tested. One of these has to be examined in more detail. So the students have to make a prediction based on this existing idea, which could be inquired through inductive learning.

Model of learning through inquiry: Stages

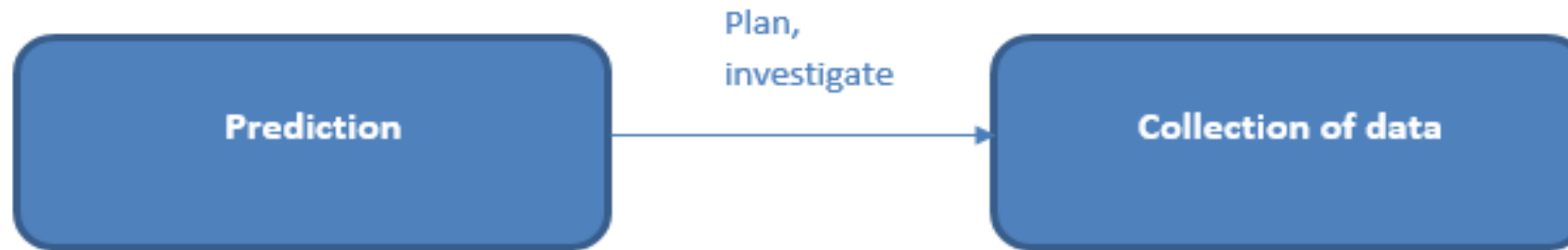

In the next step an investigation is conducted to see whether there is evidence to support the prediction. Therefore the students have to plan exactly which research activities are carried out to gather appropriate information and collect data. This process has to be adapted to their scientific process skills and their scientific knowledge. It is the responsibility of the teacher to encourage students to reflect on the links between the respective results and give them sufficient time to investigate the prediction. That enables the students not only to generate more scientific knowledge, but also to enhance their scientific process skills.

Model of learning through inquiry: Stages



It is quite often, that scientific education is finished with the collection of data. But it is necessary that the students compare the collected data and the results with the predictions they have made. Then they will find out, if the results can explain the prediction or if they have to repeat the process and test the prediction in different ways.

Model of learning through inquiry: Stages

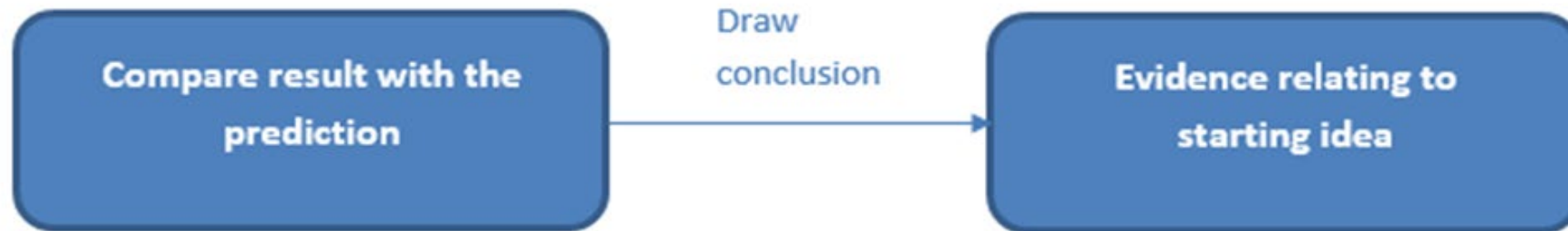

If the prediction was suitable, the conclusions from the tests are used for evidence relating to the starting idea. The students have to find out whether or not the starting idea provides a good explanation of the new experience or if it could be a solution to the initial problem.

Model of learning through inquiry: Stages

If the evidence shows that the starting idea gives a good explanation, it can be linked with the previous experience. Therefore it is helpful, when the students communicate and report their research process. Then they are able to take a different perspective, reflect the process and relate it to the previous knowledge, so that it can be extended. So a small idea or a specific problem becomes a “bigger” (but not confirmed) idea by learning through inquiry. This bigger idea relates to several situations and could be generalized to a set of phenomena. If the starting idea hasn't provided appropriate explanations an alternative idea must be found and investigated.

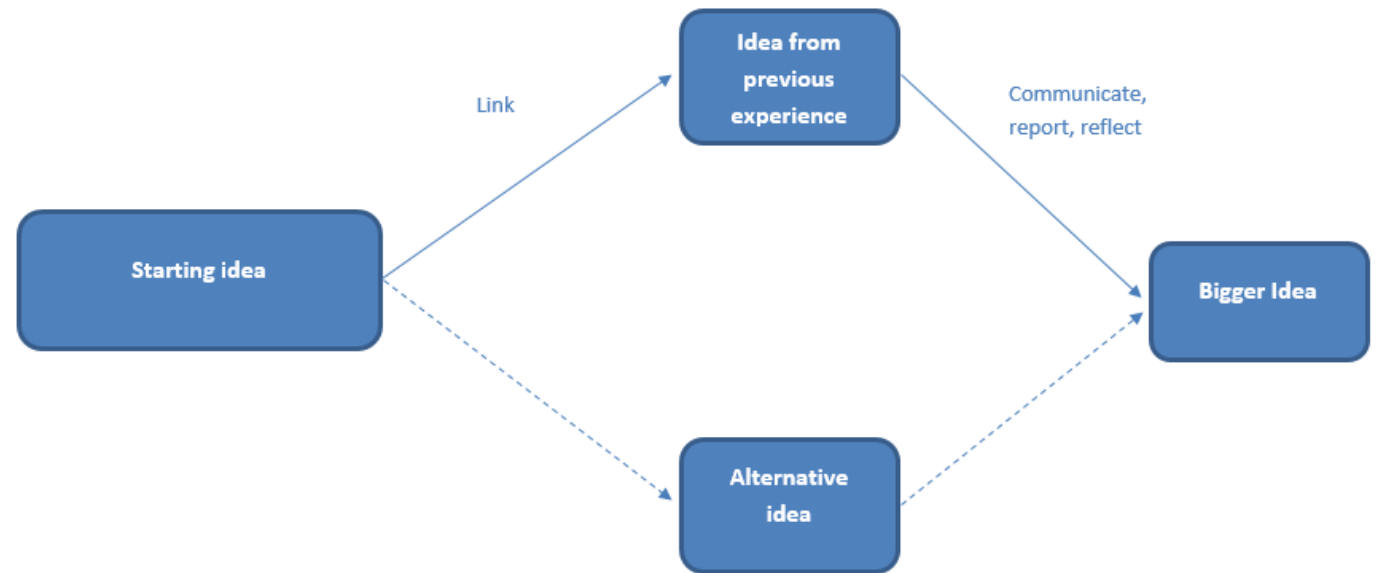

Content

1. Teaching science for understanding

- Main Idea: Why teaching science? What science should we teach?
- Big Ideas of Science
- How to develop Big Ideas

2. Model of learning through inquiry (Wynne Harlen)

3. Science process skills

4. Examples of activities

Science process skills

During the described process of research-based learning, not only knowledge is generated, but also many scientific process capabilities are claimed, practiced and further developed. These skills are clarified in the following slides.

It is not only important to know, that these skills are promoted by learning through inquiry, but it is also important how the teacher can encourage the students, give hints and guide by asking the right questions.

In doing so, the teacher can use several questions which are adapted to the state of development of the students and the research process. These questions enable students to verbalize their thinking and ideas, encouraging the use of research skills, strengthening collaboration and interaction, and helping students to reflect their actions.

Appropriate questions regarding the respective activity or to encourage the specific capabilities can be found below in the blue boxes.

Science process skills: Raising questions and planning inquiries

At the beginning of the research it is important to activate the children's prior knowledge and to let them develop their ideas. In this way, the interests and experiences of the students are focused and taken up again within the process so that the students can identify themselves with the prior question. Thus it is important that the students find hypotheses and make initial predictions which can be investigated. This investigation has to be planned. The role of the teacher is to encourage and support the students according to their interests and stage of development.

Teachers' questions to encourage student's questioning and planning:

- What would you like to know about...?
- What do you think will happen if your idea is correct?
- What do you think will happen if ... or when ...?
- What do you think will make this go ...?
- What will you need to do to find out ...?
- How will you make it fair?

Science process skills: Gathering information

There are many ways to gather information or to collect data. In primary school observation is most popular. In doing so, processes such as observing details, finding similarities and differences or patterns and relationships are promoted. The role of the teacher is to give the students the opportunity to observe and to encourage and support them according to their needs. The students can be given the opportunity to work with instruments such as a microscope or to use pictures and models. Furthermore all sorts of tables, diagrams, graphs, charts, figures e.g. are suitable for the observation. Besides additional sources, for example a computer, help the students to gather information. In summary, these aspects enable the students to observe detailed and targeted. That is important, because only in this way reliable data can be collected to show if the ideas and predictions are correct and deliver results that can amplify existing knowledge.

Teachers' questions to encourage skills for gathering information by observing:

- What do you notice that is the same about these ...?
- What differences do you notice between the ... of the same kind?
- What differences do you see when you look through the lens?
- How much longer (heavier, etc.) is this than ...?
- What did you notice about places where you found the most ...?
- What more can you find out about ... from the books and the internet?

Science process skills: Analyzing, interpreting and explaining

An important part of the scientific research process is to give students the opportunity to use the results of their research to enhance their understanding of scientific phenomena. Therefore it is not only necessary to observe a transformation, but also to find explanations why this arises. For this reason, it is important to look at the predictions taken from different perspectives and to examine them in many ways in order to grasp the phenomenon as comprehensively as possible and to compare the results with the starting idea. The role of the teacher is not to give the students complete answers, but instead to encourage them to test their predictions many times and connect their observations with their prior knowledge. In summary, these process skills enable the students to analyze the results precisely and to discover more and more facets (and their interactions) of the phenomenon.

Teachers' questions to support analysis and interpretation:

- How did what you found out compare with what you expected?
- Did you find any connection between ... and ...?
- What did you find makes a difference to how fast ... how far ... how many ...?
- What do you think is the reason for ...?
- What would you expect if ... ?
- Would ... or ... explain better, what you found?

Science process skills: Communicating, arguing, reflecting

These skills enable students to make their thinking "visible" to themselves and others. By exchanging information with or present results to their classmates the observations and the whole research process is reflected. During the communication with others, students are challenged to verbalized their thinking and to take a different perspective. Thus they revisit their findings from this perspective. Therefore on the one hand information is passed on, but on the other hand new ideas and questions are generated, explanations are found together, (new) knowledge is built up (because you get to know a different perspective from your own) and the own view is considered critically. The role of the teacher is to encourage students to verbalize their thinking, to communicate with each other and to provide them with appropriate materials to present their findings to the others.

Teachers' questions to support communication skills:

- Can you explain that a little more?
- How are you going to keep a record of what you do and find?
- What kind of chart/graph/drawing do you think is the best way to show the results?
- How can you explain to the others what you did and what happened?
- How can you show that (what evidence do you have that) your conclusion is right?
- What other conclusions can you draw from your results?

Content

1. Teaching science for understanding

- Main Idea: Why teaching science? What science should we teach?
- Big Ideas of Science
- How to develop Big Ideas

2. Model of learning through inquiry (Wynne Harlen)

3. Science process skills

4. Examples of activities

Examples of activities

Explanation of principles using examples of activities

Activities proposed in the project are aimed at various aspects of content, process and whole nature of science development. Using the activities, we are trying to develop:

- targeted and detailed scientific observation;
- scientific measuring as a tool for gathering reliable evidence;
- making scientific predictions that connects actual evidence with prior knowledge;
- scientific categorization which leads to systematization of prior knowledge;
- proposing own inquiry procedure leading to support of responsibility and competency;
- sensitiveness to information sources credibility;
- interfering and work with systematized data;
- scientific accuracy and skepticism.

Development of targeted and detailed scientific observation

Observation can be perceived as a basic scientific tool for collecting data. More data we obtain, better understanding we can expect. Scientific observation, comparing the everyday one, is **detailed** and **targeted**. Primary pupils have usually feeling, that they already know the phenomena of their surroundings. Particular activities lead the pupils to detailed observation of these phenomena and pupils find that still it is possible to learn something new.

In this activity, pupils are asked to make as many „copies“ of one coin as is possible using two mirrors touching each other by borders (as on the picture). The teacher encourages them to be very precise in their observation: Let's try it! Other pupils were able to create 60 copies of one coin. Will you be able to manage it as well? Is it possible to create never-ending amount of „copies“? Further the pupils are led to investigate how the mirror reflection is created.

Úloha 5a: Pozorujte vznik odrazu mince v zrkadle v dvoch rôznych situáciách. Spočítajte, koľko mincí v zrkadlách vidíte. Z pozorovania vytvorte záver.

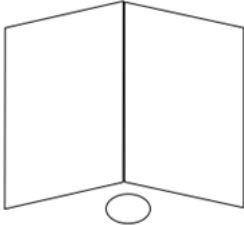
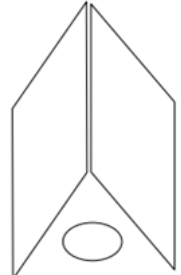
	
Počet mincí:	Počet mincí:
Záver:	

Úloha 5b: Pokúste sa meniť pozíciu zrkadiel tak, aby ste získali čo najviac mincí v zrkadlách. Zistite, či závisí počet zobrazených mincí od veľkosti mince? Závisí počet zobrazených mincí od veľkosti zrkadiel? Sú všetky obrazom tej istej reality – mince?

Nákres:	Odpoveď:
---------	----------

Úloha 4c: Vedeli by ste vytvoriť nekonečné množstvo mincí v zrkadlách? Nakreslite, ako by ste umiestnili zrkadlá k sebe a kde by bola minca. Vysvetlite, prečo vidíte toľko obrazov mincí v dvoch zrkadlách, ak viete, že jedno zrkadlo dokáže vytvoriť len jeden obraz mince.

Development of targeted and detailed scientific observation

Most often pupils observe reality. But observation skill can be developed by **using pictures and models** as well. To be sure they develop observation skill, they should be asked to use their prior knowledge. We use this kind of activities when it is not possible to observe real objects.

Pupils are asked to draw their idea about how the blood is situated in a human body. They are also asked to make connection between blood and heart, if they think there is any connection. While drawing, pupils use their preconceptions and questions are usually rising up – they are not sure about many particular things of the human blood system. Once the teacher gives the pupils credible source of information – for example encyclopedias, they are observing on the pictures exactly the details they were not sure about – observation is detailed and targeted.

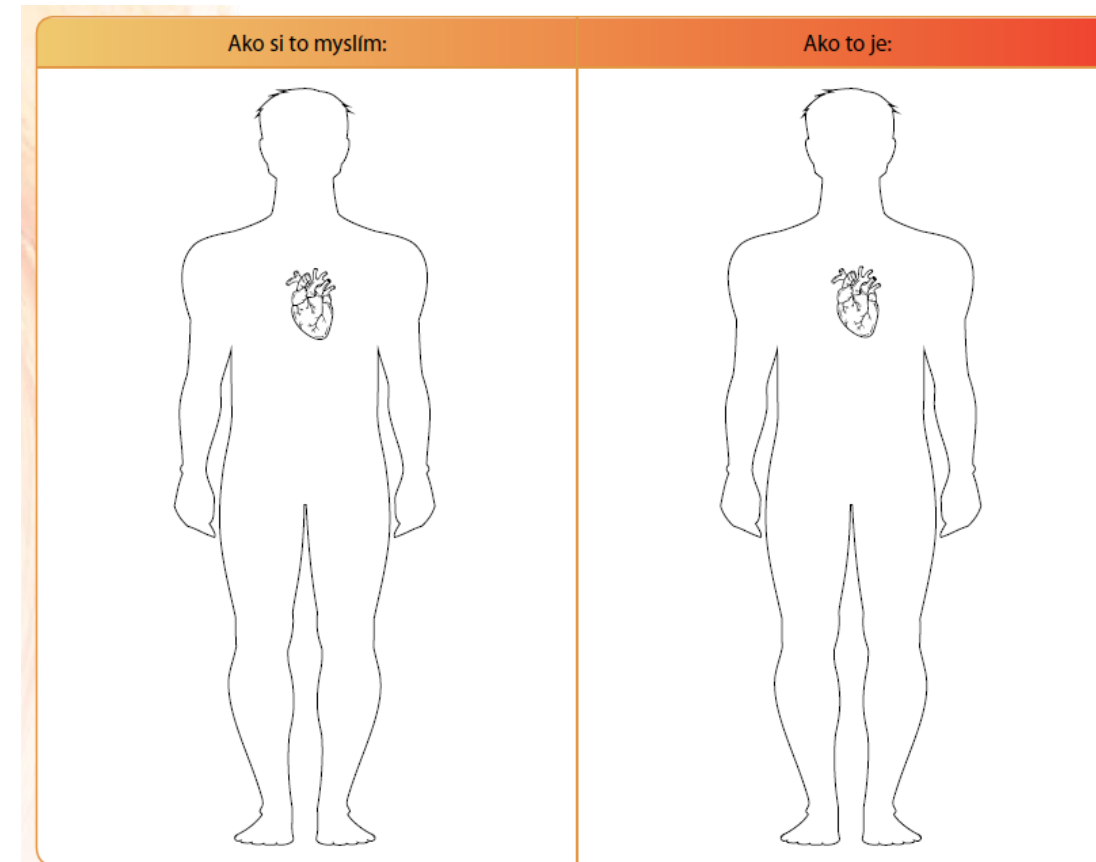

Development of targeted and detailed scientific observation

Pupils can observe information in tables, diagrams, graphs, charts, figures. According to specific task, they should „observe“ the information to get the answer. When pupils are making conclusion, the knowledge is more stable, because it was created on the basis of data, using logical thinking.

Various systematized data accessible on internet could become an interesting motion to start scientific observation. For example, in this task, the pupils are asked to observe lunar calendar for actual year. The task is to find out how many days pass from one full moon to another. Further they are asked to observe moon on sky for next two weeks and compare the obtained data with the lunar calendar.

3 V tabulke sa nachádza prehľad fáz Mesiaca v roku 2018. Vyznač spln a nov v každom mesiaci (nov je vyfarbený kruh). Koľko dní prejde od jedného splnu k druhému?

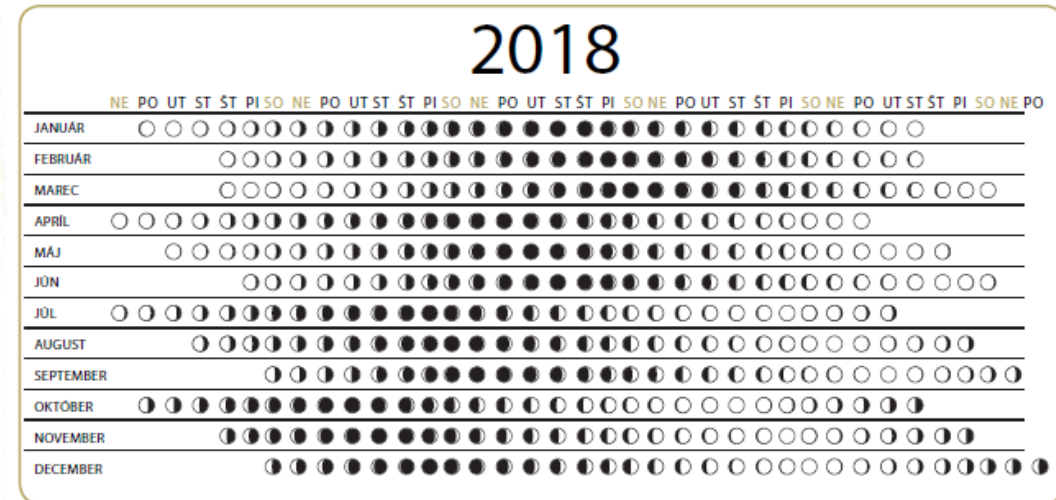

4 Nájdi na internete fázy Mesiaca na nasledujúce dva týždne a vyznač fázy do tabuľky. V dňoch, keď bude bezoblačná noc, pozoruj Mesiac na oblohe a zhoď, či pozorovanie súhlasí s údajmi, ktoré sú na internete.







Dátum																								
Internet																								
Pozorovanie																								

Development of scientific measuring as a tool for gathering reliable evidence

Measuring skill makes the observation more precise, thus the data become more reliable. To develop the skill the teacher should be aimed at **preciseness** and **repeated measurement**, just to be sure the chance of mistakes is decreased. In many activities universal measurement tools are used, but measurement skill can be very effectively developed in a case the pupils are asked to propose own measurement tools.

In this activity, the pupils observe friction of various materials using magnetism. They are asked to find out distances from which the same magnet attracts the same paper clip in a case the paper clip is placed on different surfaces (paper, fabric, plasticine). Besides repeated measurement, the pupils are asked to move with magnet very slowly, to place the paper clip the same way, etc. – they are asked to make the measurement precise way. Finally they are asked to explain, what caused the observed differences.

Úloha 19: Zistite, či ten istý magnet pritiahne tú istú spinku z rovnakej vzdialenosti, ak sa spinka pohybuje po rôznych povrchoch. Meranie pre každú spinku opakujte tri krát. Z pozorovania vytvorte záver. Čo spôsobilo zistené rozdiely?

Po papieri												
Po flise												
Po plastelíne												

magnetický predmet	vzdialenosť magnetického predmetu od magnetu pri jeho pritiažení							
	magnet 1				magnet 2			
	opakované merania				opakované merania			
	1	2	3	4	1	2	3	4
spinka na spisy								
klúč								
minca								





Development of making scientific predictions that connects actual evidence with prior knowledge

Most of the activities are aimed at development of various science process skills while specific ideas of and about science are developed as well. Sometimes it is very difficult to distinguish between development of particular science process skills. Skill of making predictions is very typical for scientific process. To be sure the pupils are **not just guessing**, the teacher asks not only the prediction statement, but **asks for its reasoning** – using what kind of prior knowledge the pupils created the prediction. This process highlights the **connection between prior knowledge and actual inquiry process**.

Pupils are asked to mark that prediction they agree with. It is easier way of making prediction comparing the situation in which the pupils are asked to formulate own statement. The pupils are asked to make prediction about relation between length of the pendulum string and its oscillation.

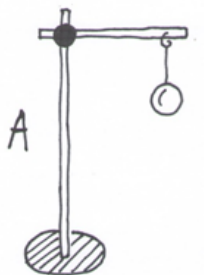
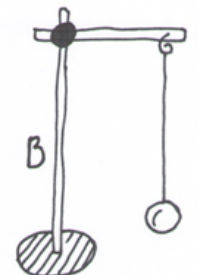
Úloha 3: Výskumná otázka: Závaží kyvadla závisí rýchlosť kývania kyvadla od toho, na akom dlhom špagáte je kyvadlo zavesené? Označte predpoklad, s ktorým súhlasíte. Predpoklad si overte a výsledok zaznamenajte.

Predpoklady								
Myslím si, že obe kyvadlá sa budú kývať rovnako rýchlo.								
Myslím si, že kyvadlo sa bude kývať rýchlejšie, keď bude na dlhšom špagáte.								
Myslím si, že kyvadlo sa bude kývať rýchlejšie, keď bude na kratšom špagáte.								
		 <p>počet kmitov</p> <table border="1"> <tr> <th>kyvadlo</th> <th>počet kmitov</th> </tr> <tr> <td>A</td> <td>20</td> </tr> <tr> <td>B</td> <td>20</td> </tr> </table>	kyvadlo	počet kmitov	A	20	B	20
kyvadlo	počet kmitov							
A	20							
B	20							
Počet kmitov:	Počet kmitov:							
Zhodnotenie predpokladov a odpoveď na výskumnú otázku:								

Development of scientific categorization which leads to systematization of prior knowledge

An activity develops categorization skill in a case the teacher discusses with pupils **criteria of sorting**. The criteria for every particular category should be set very precise way. For example, we can say that the object is not attracted to a magnet only in a case, we did not observe any indication of attraction using various magnets and observing all sides of the object.

In this activity, pupils are asked to make predictions about magnetic attraction of various objects. Categorization of the objects is on two levels and helps the inquiring person to discover inductive conclusion – only specific materials are attracted to magnets. Pupils are asked to observe wooden, metal and plastic objects. Using this kind of categories the teacher highlights the important differences between the objects.

Výskumná otázka 1:

AKÉ PREDMETY SÚ PRIŤAHOVANÉ MAGNETOM?

	Druh materiálu a predmetu	Predpoklad	Overenie
Predmety z dreva		gombík	
		kocka	
		lyžica	
		konár	
Predmety z kovu		minca	
		klúč	
		lyžica	
		podkova	
Predmety z plastu		gombík	
		hrebeň	
		lyžica	
		fľaša	
Záver z pozorovania a odpoveď na výskumnú otázku:			

Development of proposing own inquiry procedure leading to support of responsibility and competency

To support ability to create own procedure which can lead to verification of own way of thinking about observed phenomenon, pupils should have possibility to discuss their ideas in small groups. It is also very important to build up an idea that **inquiry procedures are not designed by someone else in advance**, the inquiry procedures are designed by inquiring person him/herself. If the pupils are proposing their own procedure for verification of predictions, they really understand the situation, feel responsibility for conducting the procedure, know well what to do and why and **fell themselves as competent inquirers**.



In this activity, pupils are asked to discuss everyday situation and further to propose a procedure how to find out which explanation fits the best the observed phenomenon – thermal insulation.

1. Mark the statement you agree with. In a case you do not agree with any of the statements try to express your own explanation.
2. Discuss the conditions in which you would agree with the pupils you disagree now.
3. Design a procedure you can use for verification of your prediction.

Development of sensitiveness to information sources credibility

Credibility of informational sources is possible to be solved directly, for example by **considering inconsistent or directly contradictory information**. Pupils use logical reasoning to decide which informational sources provide more or less credible information.

For example, in this activity, pupils are reading information from 4 different sources of information. While information provided by 3 of them are mutually consistent, the 4th one provides inconsistent information. Pupils understand, that it is important to check information in different sources.

6 Prečítaj si články z novin informujúce o množstve vzduchu, ktoré človek potrebuje na dýchanie.

Priemerný dospelý človek vdýchne pri jednom nádychu asi pol litra vzduchu. Pľúca stále uskladňujú asi 3 litre vzduchu. Udržiavajú si stále množstvo bez ohľadu na to, ako dýchame, a správajú sa ako bezpečnostné zariadenie, chránia telo pred náhlymi zmenami prostredia.

<https://www.personaloxxygen.eu>

Podľa správy TASR každý strom denne vytvorí 180 litrov kyslíka. Človek denne v pokoji spotrebuje až 360 l kyslíka. Na to, aby mohol denne dýchať, teda potrebuje 2 stromy. V prípade, že vyvíja nejakú činnosť, potrebuje stromov ešte viac.

17. apr. 2005 o 14:47, TASR

Ročná spotreba kyslíka dospelého človeka je asi 330 kilogramov. 100 rokov starý buk vytvorí za jednu hodinu asi 17 kg kyslíka, čím zabezpečuje ročnú spotrebu desiatim dospelým ľuďom.

<http://www.lesnapedagogika.sk>

Každý vie, že človek potrebuje na dýchanie kyslík, ktorý sa nachádza vo vzduchu. Vieme aj to, že kyslík tvoria rastliny. Málokto však vie, koľko kyslíka človek potrebuje, a tiež je málo známe, koľko kyslíka vie rastlina vyrobiť. Americkí vedci zistili, že na dýchanie človeku postačí len jedna stredne veľká izbová rastlina a nemusí ani vetrať.

<http://www.novinarske-kacice.sk>

Read the information about amount of air one person needs for breathing.

- **Which information surprised you?**
What interesting and new you found about breathing?
- **Have you found any contradictory or inconsistent information?**
Is it possible to discredit any of the informational sources? Explain.

Development of interfering and work with systematized data

Work with various data is for understanding nature of science very important. Finally it leads to understanding that scientific explanations are those ones which are in best accordance with facts known in specific time.

Process of **systematization** of data **highlights compared variables** and **facilitates making conclusion** so the researcher perceive the credibility of the conclusion – he/she understands it as a real outcome (explanation) of what was observed.

7 Porovnaj informácie na obrázkoch a vytvor z porovnania záver.

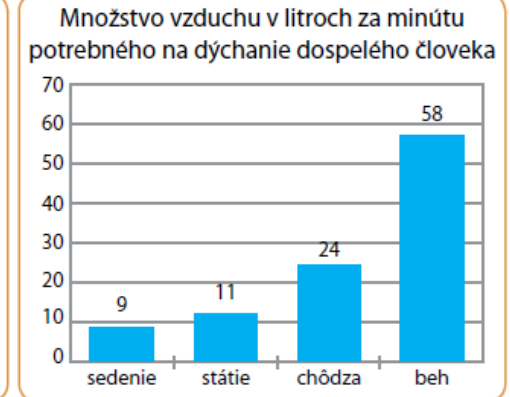
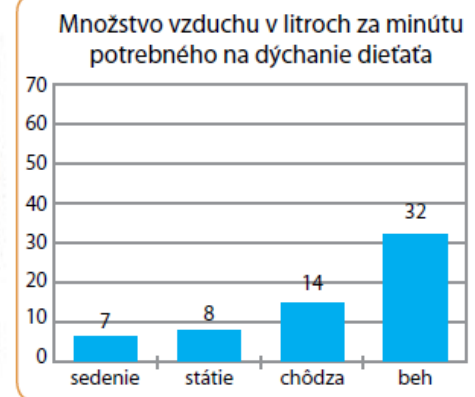

Záver:

Compare information out of two diagrams and make conclusion.

Pic 1: Amount of air in liters one child needs for breathing per one minute (sitting, standing, walking, running).

Pic 2: Amount of air in liters one adult needs for breathing per one minute (sitting, standing, walking, running).

Development of inferring and work with systematized data

In most of the tasks, pupils are asked to infer using empirical data obtained in the actually realized inquiry. But inferring skill can be developed using various data. Some of the activities are leading pupils to use inferring skills while studying various traditional systematized data. Pupils are aimed to inquiry data, trying to use logical thinking and all their previous knowledge – they infer the answer.

In this task, pupils are asked to observe map of a specific mountain area. Their attention is aimed at springs and rivers. They are asked to use knowledge about gravitation force and apply this knowledge using the data from the map to indicate, which marked points are placed lowest, highest and on same altitude.

Úloha 7: Pozorujte na mape množstvo potokov a podľa vedomostí o pôsobení gravitačnej sily na kvapaliny sa pokúste určiť, ktoré body na mape sú najnižšie položené, ktoré najvyššie a ktoré sa nachádzajú v rovnakej výške.

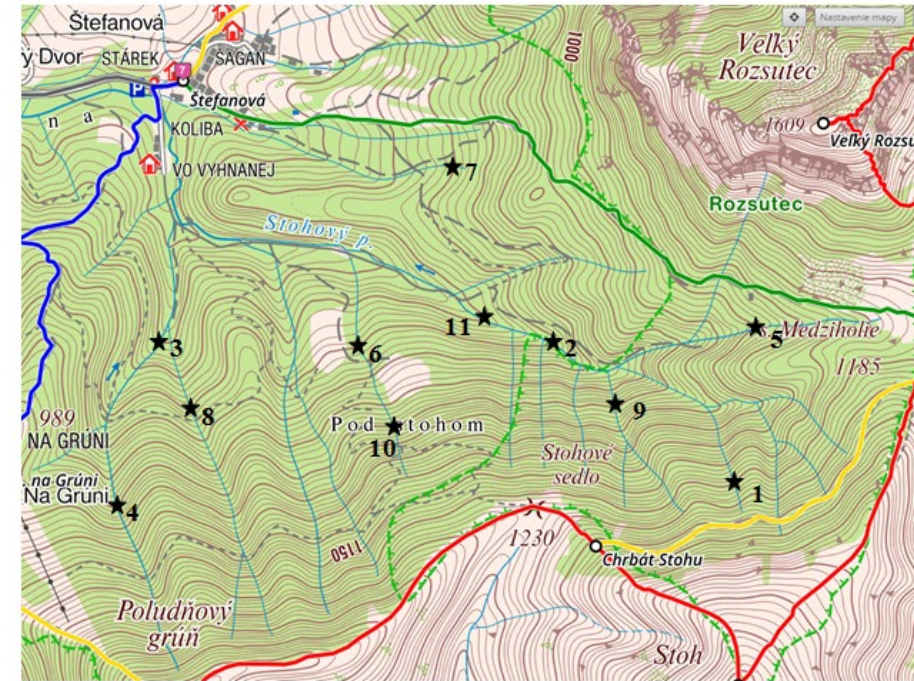

Svoje predpoklady si overte pomocou vyhl'adávania na internete.

Development of scientific accuracy and skepticism

Skepticism is, similarly to accuracy, one of the fundamental features of the scientific thinking process. While developing ideas about the nature of science, it is important to be aimed on development of **appropriate level of skepticism**. Pupils should understand that they have to **make conclusions very carefully**, not uttering them as indubitable facts. They should be very careful while they are getting information from various sources. Pupils should express their tendency for verification of the credibility of offered information or explanations.

O prekonávaní gravitácie sa čím ďalej tým častejšie uvažuje aj pri návrhoch nových áut.
Prezri si obrázok. Čo myslíš, je tento návrh vznášajúceho sa auta vymyslený alebo auto skutočne existuje?



Čo si zistil/zistila?

Tip: Na vyhľadávanie informácií o vznášajúcich sa autách na internete použite nielen slovenské kľúčové slovo: *vznášajúce sa auto*, ale aj jeho anglický preklad: *hover car*.

On the picture pupils see a hovering taxi car. Their task is to find out whether it really exists. They can use various sources of information, while they should have a tendency to verify any information they will find by trying to find confirmative information in different information sources. The teacher leads the pupils' attention to the consideration of the credibility of the sources they use.

Project: I – S.K.Y.P.E. (Interactive Science for Kids and Youngsters in Primary Education)

This project has been funded with the support of the Erasmus+ Programme, K2 Action, Strategic Partnerships in School Education.

Project Agreement Number: 2016-1-SK01-KA201-022549

Conclusion:

The process used for building up scientific ideas is the same important as the obtained knowledge itself. Pupils should be able to continuously work with their understandings of the world and they should understand the significance of science in society.

The current publication reflects only the author's view and neither the Slovak National Agency, nor the European Commission are responsible for any use that may be made of the information it contains.

Project: I – S.K.Y.P.E. (Interactive Science for Kids and Youngsters in Primary Education)

This project has been funded with the support of the Erasmus+ Programme, K2 Action, Strategic Partnerships in School Education.

Project Agreement Number: 2016-1-SK01-KA201-022549

References:

HARLEN, W. (ed.) 2010. *Principles and big ideas of science education*. Herts : Association for Science Education. ISBN: 978086357 4 313. [online]. [cit. 2016-07-07].
Available online: www.ase.org.uk

HARLEN, W. (ed.) 2015. *Working with Big Ideas of Science Education*. Science Education Programme of IAP : Trieste. ISBN: 9788894078404. [online]. [cit. 2016-07-07]. Available online :
<http://www.interacademies.net/>

The current publication reflects only the author's view and neither the Slovak National Agency, nor the European Commission are responsible for any use that may be made of the information it contains.

Project: I – S.K.Y.P.E. (Interactive Science for Kids and Youngsters in Primary Education)

This project has been funded with the support of the Erasmus+ Programme, K2 Action, Strategic Partnerships in School Education.

Project Agreement Number: 2016-1-SK01-KA201-022549

I-S.K.Y.P.E.

Interactive Science for Kids and Youngsters in Primary Education – Big Idea 4

“The total amount of energy in the Universe is always the same but can be transferred from one energy store to another during an event”

The current publication reflects only the author’s view and neither the Slovak National Agency, nor the European Commission are responsible for any use that may be made of the information it contains.

What am I to expect?

This workshop wants to help you gain insight in Big Idea No. 4 “The total amount of energy in the Universe is always the same but can be transferred from one energy store to another during an event” and wants to encourage you to introduce this basic phenomenon to scientific education in primary school. One aim is to use the existing knowledge and interests of the students and to empower them to encounter the subject matter self-directed. Sole knowledge acquisition is not central, but students should gain central (process) abilities for scientific research. In your role as a teacher, you are invited to reflect your own behaviour in the interaction with students and to adjust it adequately to the current stage of development. For this matter questions play a central role. The provided material does not only enable your students to expand their existing knowledge through new experiences and scientific process skills, but will also help you to re-discover your own role as a supportive coach and to investigate basic scientific phenomena together with your class.

To get an overview about how to design your lessons you can find a description, which aspects of the scientific phenomenon students in elementary schools are able to understand, on the following pages. Additionally, several tasks, which can be found in the materials, are explained theoretically. This shows which scientific process skills can be learned and developed by which of the tasks and how you can coach students by inspiring questions for example. Furthermore, the structure of the didactical material, which can also be downloaded, is described.

Content

- 1. Introduction of the Big Idea 4 and what elementary school students are able to understand**
- 2. Examples for the implementation of the contents from Big Idea 4**
- 3. Structure of the material**
 - Didactic procedure: Teacher's part
 - Didactic procedure: Worksheets for students

Big Idea No. 4

The total amount of energy in the Universe is always the same but can be transferred from one energy store to another during an event

Many processes or events involve changes and require an energy source to make them happen. Energy can be transferred from one body or group of bodies to another in various ways. In these processes some energy becomes less easy to use. Energy cannot be created or destroyed. Once energy has been released by burning a fossil fuel with oxygen, some of it is no longer in a form that is as convenient to use.

Big Idea No. 4

The total amount of energy in the Universe is always the same but can be transferred from one energy store to another during an event

What are elementary school students able to understand?

There are various ways of causing an event or bringing about change in objects or materials. Objects can be made to change their movement by pushing or pulling. Heating can cause change, as in cooking, melting solids or changing water to vapour. Electricity can make light bulbs glow. Wind can rotate the blades of wind turbines.

In all these changes, energy is transferred from one object, which is an energy source or resource, to another. Fuels such as oil, gas, coal and wood are energy resources. Some energy resources are renewable, such as those produced by wind, waves, sunlight and tides, others are non-renewable such as from burning fossil fuels with oxygen.

Content

1. Introduction of the Big Idea 4 and what elementary school students are able to understand

2. Examples for the implementation of the contents from Big Idea 4

3. Structure of the material

- Didactic procedure: Teacher's part
- Didactic procedure: Worksheets for students

Big Idea No. 4: Worksheet 1: Reflection

Raising questions and planning inquiries

Procedure:

The teacher poses the question to the whole class.

„What comes to your mind concerning the topic energy? Think about/write down what comes to your mind.“

Every student thinks about the topic by him-/herself first.

Teaching aids: papers and pencils for notes

Educational objective: *Gathering of information based on the children's prior knowledge. Preparatory exercise for later collection of information based on observation or secondary sources like books.*

Big Idea No. 4: Worksheet 1: Reflection

Raising questions and planning inquiries

What comes to your mind concerning the topic energy? Think about/write down what comes to your mind!

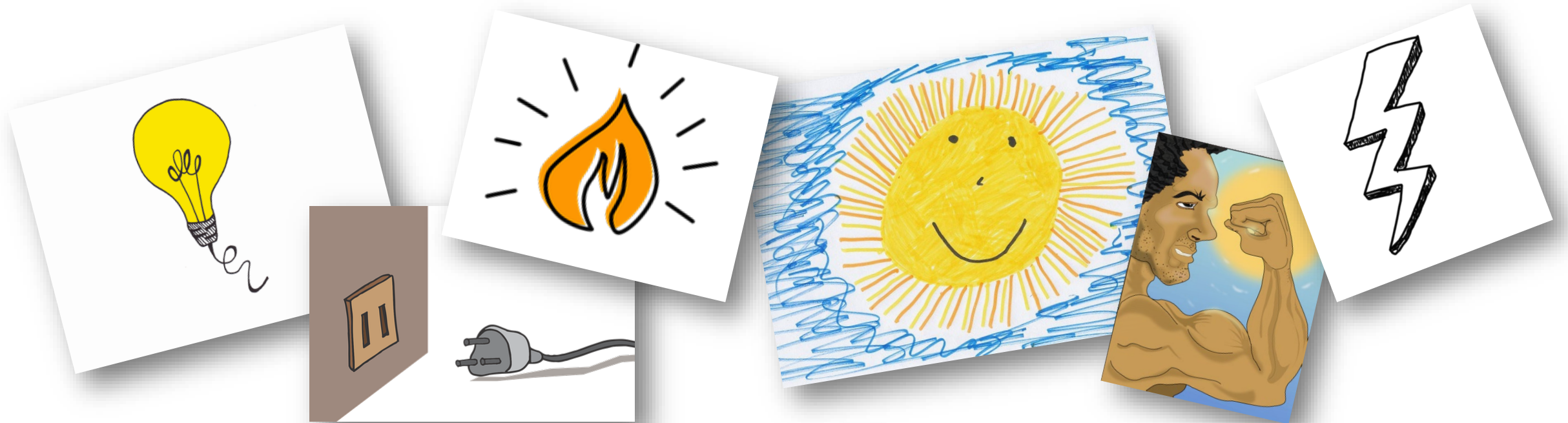

Big Idea No. 4: Worksheet 1: Reflection

Raising questions and planning inquiries

How do I adapt the task to my student's abilities?

- The job to collect at least three (or more) aspects can be given to stronger children.
- Weaker children may work in groups of two.
- Depending on the ability to write the ideas can be written down, drawn or kept in mind. In the latter case the phase should be very brief (1-2 minutes), drawings take longer.

Big Idea No. 4: Worksheet 1: Reflection

Raising questions and planning inquiries

Previous knowledge is a key base in creating new knowledge. Students are primed individually for the (research) process through the activation of their own knowledge. Thus they are ready to integrate the new experience in their previous existing knowledge and to compare them. Hence resulting discrepancies lead the children to dig into new things.

This way motivation to think about a so far assumed aspect more thoroughly or to see it in a different perspective is created. Own ways of thinking or ideas will be „examined“ and it will be practised thereby to evolve questions, to be curious and to plan next steps. Conceptions about possible relationships or procedures are „thought up“.

During this activity children think about everything that concerns energy. The task illustrates, where energy is relevant in children’s living environment. Through noting or drawing the students deal with what they already know about the term energy. Energy is used in everyday life entirely naturally, as for example by listening to music or by driving the car. But is this all the same energy?



Big Idea No. 4: Worksheet 1: Reflection

Raising questions and planning inquiries

Hints for implementation

This task has the purpose to activate the children's previous knowledge and giving them the opportunity to generate their own ideas. They in part need more or need less assistance through the teacher. This can be done by questions, like „What will happen, if...?“, „What in particular do you want to know?“ or „What exactly do we need to do in order to see/hear/experience this?“.

Big Idea No. 4: Worksheet 1: Reflection

Raising questions and planning inquiries

Hints for implementation

How well am I doing as follows (already)?

- I encourage children to verbalize their ideas about relationships.
- I attach importance to an open-minded discussion atmosphere in class.
- I offer the opportunity to children to find out that there are different ideas concerning the same fact (for example through small group discussions or discussions with the whole class).
- I encourage children to write down their ideas/expectation or to draw them.
- I encourage children to think about what kind of relationships there are (“Which are the influencing factors?” or “Which features are going to change?”)

Further ideas for other material:

- I assist children to think about, what exactly they want to investigate and how they want to observe effects.
- I encourage children to generate first prognosis and predictions, which can be tested.

Big Idea No. 4. Worksheet 5.1: Picture puzzle

Gathering information

Procedure:

The picture on the worksheet or another suitable picture can be used. The instruction is:

„Look at the picture! What needs electricity?
Mark in the picture and write down!“

Teaching aids: worksheet



Look at the picture! What needs electricity?
Mark in the picture or write down, what your students might say!



Look at the picture! What needs electricity?
Mark in the picture or write down, what your students might say!

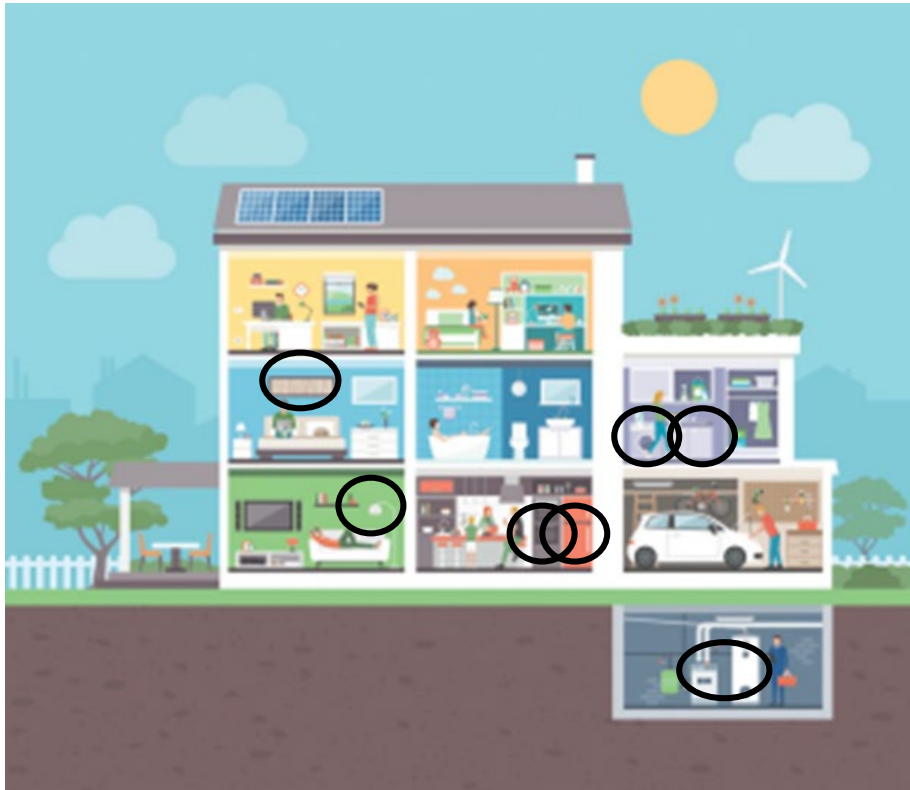

Possible solutions:

z.B. lamp, air conditioning, stove, fridge,
washing machine, dryer, heating system...

Big Idea No. 4. Worksheet 5.1: Picture puzzle

Gathering information

Observation can be perceived as a basic tool for collecting data in the scientific process in order to collect data. What differentiates scientific observation, comparing to an everyday one, is that it is **more detailed** and **targeted**. These activities lead pupils to new discoveries in their environment and show them that it is still possible to learn something new and notice it differently. It is of great importance to guide pupils in the observation of this phenomena according to their stage of development and to create situations in which they have the opportunity to gain new abilities and build on their knowledge. Thus the more we find out, the more we are able to understand in the future.

In this activity children search for any object etc., that needs electricity. Some objects might not be identified by the children or they don't know that they need electricity. This doesn't need to be corrected. If there are different assumptions in class discussion or in small groups a comparison can be created with the following questions: „Whereby may I notice, whether electricity is needed? How is the case for the relevant item?“



Big Idea No. 4. Worksheet 5.1: Picture puzzle

Gathering information

Hints for implementation

In the phase of targeted observation or gathering information, the previous knowledge of the pupils is included on purpose. Processes like observing details, finding similarities and differences or as well patterns and relationships, are promoted by observation or data collection. The process can be implemented in terms of questions, like „What has happened, as...?“, „What differences do you notice between...?“. „What are you thinking...?“-questions might offer the opportunity to students to speak about speculations or even imperfect ideas, without having the „right“ answer ready.

Big Idea No. 4. Worksheet 5.1: Picture puzzle

Gathering information

Hints for implementation

How well am I doing as follows (already)?

- I encourage the students to recognize differences and similarities ("If you compare ... and ... what is different?", "What do you think is the same in different situations?").
- I give the students enough time for their observations.
- I offer students the opportunity to share their observations and ideas with others.
- I encourage the students to include other sources for seeking information (e.g. pc programs).

Further ideas for other material:

- I offer students opportunities to expand their observations (e.g. with magnifying glasses, a microscope, thermometers).

Big Idea No. 4: Worksheet 5.2: Picture puzzle

Analyzing, interpreting and explaining

Procedure:

The students discuss their results in groups.

The instruction is:

„What did you find in the picture?“ and „Which of them produces light, movement or temperature?“

The students can add their results in the table.

Teaching aids: worksheet

object	light	movement	warmth	other
lamp	X		X	

Big Idea No. 4: Worksheet 5.2: Picture puzzle

Analyzing, interpreting and explaining

Reworking during class discussion (with the following central questions):

Why becomes electricity sometimes light and sometimes movement?

If the term energy is not be mentioned:

Which other words do you know for the term electricity?

If the term energy is mentioned during class discussion, it is important to explain that light, movement and temperature are also energy.

What happens to the electricity?



object	light	movement	warmth	other
lamp	X		X	
car	X	X (e.g. airing)		
air-conditioning		X	X	
stove	X		X	
fridge	X	X	X	
washing machine		X	X	
dryer		X	X	
television (TV)	X		X	

Big Idea No. 4: Worksheet 5.2: Picture puzzle

Analyzing, interpreting and explaining

Educational objective: In a two-steps approach (sub1&sub2) the law of conservation of energy is introduced using the example of converting electricity in other forms of energy. Since this type of converting is the most common to children, each child should at least be able to find some examples and understand the basic concept with the help of a class discussion.



object	light	movement	warmth	other
lamp	X		X	
car	X	X (e.g. airing)		
air-conditioning		X	X	
stove	X		X	
fridge	X	X	X	
washing machine		X	X	
dryer		X	X	
television (TV)	X		X	

Big Idea No. 4: Worksheet 5.2: Picture puzzle

Analyzing, interpreting and explaining

How do I adapt the task to my student's abilities?

- For younger children, the "basic idea" that electricity is turned into light by the light bulb is adequate.
- Third and fourth grade students can examine how light bulbs and stoves are working.

Big Idea No. 4: Worksheet 5.2: Picture puzzle

Analyzing, interpreting and explaining

Once the students have collected initial data, it makes sense to look more closely at the data to identify and correlate the similarities and differences in outcomes. A suitable method for this is, for example, categorization. It places the observed impressions into already existing knowledge and shows connections. Thus, the investigated phenomenon can be explained better.

Through the discussions of the students, the categories activated by previous knowledge are interlinked and re-analyzed. As a result, not only the own knowledge is restructured, but also new categories are formed, that also contain the aspects of the classmate, so that the own knowledge is enhanced. The diversity of the different observations is thus transformed into a concept that shows similarities. By jointly viewing and analyzing the results, a new categorization of knowledge is implied, which better explains the investigated phenomenon.



object	light	movement	warmth	other
lamp	X		X	
car	X	X (e.g. airing)		
air-conditioning		X	X	
stove	X		X	
fridge	X	X	X	
washing machine		X	X	
dryer		X	X	
television (TV)	X		X	

Big Idea No. 4: Worksheet 5.2: Picture puzzle

Analyzing, interpreting and explaining

Students can use tables, charts, graphs, listings, drawings and more to support observation and to understand and explain their results better. When students draw a conclusion from their experiences, this is much stronger because it is built on the collected data and based on processes of logical thinking.



Tables and graphics help the students in different ways. On the one hand, they support them during the assignment because results can be recorded and documented directly. It is advisable to provide students different forms of documentation and preparation of the results, because only then they are able to process their experiences in a way that is appropriate to connect the results with the already existing knowledge. Thus, tables, diagrams, etc. give students the opportunity to engage with the topic and the results on a different level of abstraction, to look more closely at them and to "think through" them. This provides the basis for presenting and explaining the results to others.

object	light	movement	warmth	other
lamp	X		X	
car	X	X (e.g. airing)		
air-conditioning		X	X	
stove	X		X	
fridge	X	X	X	
washing machine		X	X	
dryer		X	X	
television (TV)	X		X	

Big Idea No. 4: Worksheet 5.2: Picture puzzle

Analyzing, interpreting and explaining

Hints for implementation

The aim of this task is to give students the opportunity to use the results of their research to enhance their understanding of scientific phenomena. It is not only enough to observe the results, but also to find explanations how and why this arises. For this reason, it is important to look at the predictions from different perspectives and to examine them in many ways in order to comprehend the phenomenon as comprehensively as possible and to question the starting idea. This process can be assisted with questions such as "Did you find any connection between ... and ...?", "What do you think is the reason for ...?".



Erasmus+



Big Idea No. 4: Worksheet 5.2: Picture puzzle

Analyzing, interpreting and explaining

Hints for implementation

How well am I doing as follows (already)?

- I give the students enough time to interpret and analyze their observations and results.
- I encourage the students to connect their observations with their knowledge through appropriate questions.
- I motivate the students to compare their observations with their ideas and the previous starting idea
- I adapt my assistance and explanations to the age, the abilities and experiences of the students.
- I use visual aids to clarify my explanations.
- I do not interfere the students research process by giving them any answers in advance.

Further ideas for other material:

- I encourage the students to test their predictions in different ways.



Content

1. Introduction of the Big Idea 4 and what elementary school students are able to understand
2. Examples for the implementation of the contents from Big Idea 4
3. **Structure of the material**
 - Didactic procedure: Teacher's part
 - Didactic procedure: Worksheets for students

Structure of the material: Didactic procedure: Teacher's part

1. Theoretical part of the chapter:

General information, child-specific abilities, keywords

2. Scientific background for the teachers:

Deepening information to build a knowledge base for supporting the students

3. Methodological guidelines for the teachers:

- Overview table (duration, level of difficulty, age, needed materials, educational objective)
- Worksheets

Structure of the material: Didactic procedure: Teacher's part

1. Theoretical part of the chapter:

General information is given to provide an **overview** of the topic. Furthermore the content of the specific Big Idea is described with respect to the abilities of the children. It is discussed which aspects can already be understood by elementary school students. **Keywords** represent the main aspects of the topic.

2. Scientific background for the teachers:

The information of the theoretical input are deepened and explained in detail including the underlying scientific concepts and additional knowledge. So the teacher can build a knowledge base for supporting the students when they are working with the materials and to answer their questions.

Structure of the material: Didactic procedure: Teacher's part

3. Methodological guidelines for the teachers: Overview Table

Gives an overview of all the materials of the respective Big Idea. It contains the expected duration, level of difficulty, age, which materials are needed and illustrates the educational objective of the task. The table facilitates the planning of the lesson, helps to adjust the content to the children's abilities as well as tying on their experiences.

Structure of the material: Didactic procedure: Teacher's part

3. Methodological guidelines for the teachers: Worksheets

Here you will find the specific tasks of the topic prepared for the use in the classroom. Each task contains different parts. First an assignment/work order for the students is verbalised then paired with some instructions. This captures the process and helps the teacher to give necessary instructions and pedagogical guidance. In addition, the materials which are needed are described. Furthermore there are suggestions which make it possible to adapt the task to the individual needs of the children.

Structure of the material: Didactic procedure: Worksheets for students

In a second and separate part you will find the required teaching material in form of worksheets etc. They can be duplicated and printed as required.

What would Wynne Harlen say...?

- Describe the Big Idea No. 4 with your own words.
- Which aspects of the respective Big Idea are elementary school students already able to understand?
- Which important steps in the (scientific) cognitive process of the children are there/can be enabled?
- How are they integrated in the work with the material?

Continuative literature:

- Wynne, H. (2015) (Ed.). Working with big ideas of science education. Science Education Programme (SEP) of IAP
- Wynne, H. (2015). Teaching Science for understanding in elementary and middle school. Portsmouth: Heinemann

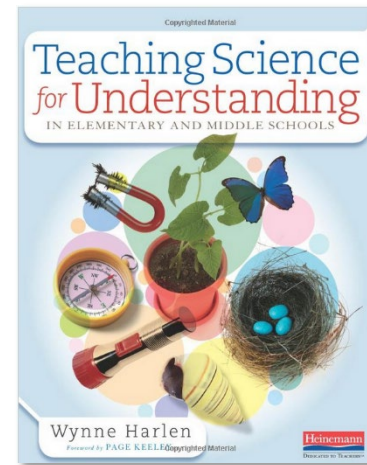

Further information:

- You can find further information and materials on our homepage <http://www.i-skype.com/> . There you will also find presentations concerning the Big Ideas No. 1,2,3,5,6,7,8,9 and 10.
- The methodical materials can be adapted in various ways to fit your class and the knowledge and interests of your students. So regarding the abilities of your students it may be useful to give additional information or to introduce other tasks and examples.



Erasmus+

Interactive Science
for Kids and Youngsters
i SKYPE

RAABE
Spoločne ku kvalitnému
vzdelávaniu



Have fun discovering the Big Ideas!



ZÁPADOČESKÁ
UNIVERZITA
V PLZNI



ZÁKLADNÍ ŠKOLA
J. GUTHA - JARKOVSKÉHO



LOUISEN LUND
LERNEN LEISTEN LEBEN



DIGITAL
CREATIVE

Project: I – S.K.Y.P.E. (Interactive Science for Kids and Youngsters in Primary Education)
This project has been funded with the support of the Erasmus+ Programme, K2 Action, Strategic Partnerships in School Education.
Project Agreement Number: 2016-1-SK01-KA201-022549

I-S.K.Y.P.E.

Interactive Science for Kids and Youngsters in Primary Education – Big Idea 7

“Organisms are organized on a cellular basis and
have a finite life span”

The current publication reflects only the author’s view and neither the Slovak National Agency, nor the European Commission are responsible for any use that may be made of the information it contains.

What am I to expect?

This workshop wants to help you gain insight in Big Idea No. 7 “Organisms are organized on a cellular basis and have a finite life span” and wants to encourage you to introduce this basic phenomenon to scientific education in primary school. One aim is to use the existing knowledge and interests of the students and to empower them to encounter the subject matter self-directed. Sole knowledge acquisition is not central, but students should gain central (process) abilities for scientific research. In your role as a teacher, you are invited to reflect your own behaviour in the interaction with students and to adjust it adequately to the current stage of development. For this matter questions play a central role. The provided material does not only enable your students to expand their existing knowledge through new experiences and scientific process skills, but will also help you to re-discover your own role as a supportive coach and to investigate basic scientific phenomena together with your class.

To get an overview about how to design your lessons you can find a description, which aspects of the scientific phenomenon students in elementary schools are able to understand, on the following pages. Additionally, several tasks, which can be found in the materials, are explained theoretically. This shows which scientific process skills can be learned and developed by which of the tasks and how you can coach students by inspiring questions for example. Furthermore, the structure of the didactical material, which can also be downloaded, is described.

Content

- 1. Introduction of the Big Idea 7 and what elementary school students are able to understand**
- 2. Examples for the implementation of the contents from Big Idea 7**
- 3. Structure of the material**
 - Didactic procedure: Teacher's part
 - Didactic procedure: Worksheets for students

Big Idea No. 7

Organisms are organized on a cellular basis and have a finite life span

All organisms are constituted of one or more cells. Multi-cellular organisms have cells that are differentiated according to their function. All the basic functions of life are the results of what happens inside the cells which make up an organism. Growth is the result of multiple cell divisions.

Big Idea No. 7

Organisms are organized on a cellular basis and have a finite life span

What are elementary school students able to understand?

There is a wide variety of living things (organisms), including plants and animals. They are distinguished from non-living things by their ability to move, reproduce and react to certain stimuli. To survive they need water, air, food, a way of getting rid of waste and an environment which stays within a particular range of temperature. Although some do not appear to be active, all will at some stage carry out the life processes of respiration, reproduction, feeding, excretion, growth and developments and all will eventually die.

Content

1. Introduction of the Big Idea 7 and what elementary school students are able to understand

2. Examples for the implementation of the contents from Big Idea 7

3. Structure of the material

- Didactic procedure: Teacher's part
- Didactic procedure: Worksheets for students

Big Idea No. 7: Worksheet 1: Hidden object picture

Raising questions and planning inquiries



Big Idea No. 7: Worksheet 1: Hidden object picture

Raising questions and planning inquiries

Procedure:

The students receive the worksheet, which contains the assignment, the hidden object picture and the table in which the answers can be entered. The teacher gives the following instruction:

„Look at the picture! What is alive and what is not alive? Find five animate and five inanimate things for the following table.“

Teaching aids: worksheet, coloured pencils (see adaptation)

Educational objective: To activate children’s knowledge and to fill and revise the concept of life or liveliness because of the recognized living creatures in the environment.



Big Idea No. 7: Worksheet 1: Hidden object picture

Raising questions and planning inquiries

How do I adapt the task to my student's abilities?

The instruction can be varied differently, for example, the found object can be marked instead of written down with different colors.

e.g.: green = alive , blue = not alive

→ Further ideas can be found in the material.



Big Idea No. 7: Worksheet 1: Hidden object picture

Raising questions and planning inquiries

Previous knowledge is a key base in creating new knowledge. Students are primed individually for the (research) process through the activation of their own knowledge.

Thus they are ready to integrate the new experience in their previous existing knowledge and to compare them. Hence resulting discrepancies lead the children to dig into new things.

This way motivation to think about a so far assumed aspect more thoroughly or to see it in a different perspective is created. Own ways of thinking or ideas will be „examined“ and it will be practised thereby to evolve questions, to be curious and to plan next steps. Conceptions about possible relationships or procedures are „thought up“.

In this activity, the children consider which things are alive or not to alive for them. For this, the prior knowledge must be activated, because every child has a different idea of the term "aliveness". This prior knowledge helps the child to perform the task and to find things in the hidden object picture that are alive or not alive. Through the application of his previous knowledge, the child recognizes things he already knows, but in addition, he/she will find out to that there are objects which can not be clearly classified as alive or not alive. This discrepancy motivates the child to study the phenomenon of liveliness in order to learn something new.



What is alive?	What is not alive?

Big Idea No. 7: Worksheet 1: Hidden object picture

Raising questions and planning inquiries

Hints for implementation

This task has the purpose to activate the children's previous knowledge and giving them the opportunity to generate their own ideas. They in part need more or need less assistance through the teacher. This can be done by questions, like „What will happen, if...?“, „What in particular do you want to know?“ or „What exactly do we need to do in order to see/hear/experience this?“.

Big Idea No. 7: Worksheet 1: Hidden object picture

Raising questions and planning inquiries

Hints for implementation

How well am I doing as follows (already)?

- I encourage children to verbalize their ideas about relationships.
- I attach importance to an open-minded discussion atmosphere in class.
- I offer the opportunity to children to find out that there are different ideas concerning the same fact (for example through small group discussions or discussions with the whole class).
- I encourage children to write down their ideas/expectation or to draw them.
- I encourage children to think about what kind of relationships there are (“Which are the influencing factors?” or “Which features are going to change?”)

Further ideas for other material:

- I assist children to think about, what exactly they want to investigate and how they want to observe effects.
- I encourage children to generate first prognosis and predictions, which can be tested.

Big Idea No. 7: Worksheet 3: Classification of living creatures

Analyzing, interpreting and explaining

Procedure:

The teacher gives the following instructions: „Discuss with other students: What did you register in your table at „What’s alive“? Can you assign these to different groups? Find names for your groups and write them down!“

This process can be divided in different periods:

Period 1: Teamwork, the teacher provides an overview and assists if its necessary

Period 2: The teams depict their classifications which are noted by the teacher

The teacher deals with the classifications of the students. There are no wrong classifications. Each of them mentioned by the students is reconsidered and used as a basis for (class) discussion.

Educational objective: Reflection about known examples of life, useful categorisation of the current knowledge, demonstration of the diversity of live and between living creatures.

Big Idea No. 7: Worksheet 3: Classification of living creatures

Analyzing, interpreting and explaining

Possible solutions of the students:

- big – small
- can move – can not move
- I like it – I don't like it
- needs food – doesn't need food

It's important that the teacher appreciates the classifications of the students and tolerates that they can be different! There are no wrong classifications! Each classification mentioned by the students should be used as a basis for (class) discussion.

Big Idea No. 7: Worksheet 3: Classification of living creatures

Analyzing, interpreting and explaining

Once the students have collected initial data, it makes sense to look more closely at the data to identify and correlate the similarities and differences in outcomes. A suitable method for this is, for example, categorization. It places the observed impressions into already existing knowledge and shows connections. Thus, the investigated phenomenon can be explained better.

Through the discussions of the students, the categories activated by previous knowledge are interlinked and re-analyzed. As a result, not only the own knowledge is restructured, but also new categories are formed, that also contain the aspects of the classmate, so that the own knowledge is enhanced. The diversity of the different observations is thus transformed into a concept that shows similarities. By jointly viewing and analyzing the results, a new categorization of knowledge is implied, which better explains the investigated phenomenon.



What is alive?	What is not alive?

Big Idea No. 7: Worksheet 3: Classification of living creatures

Analyzing, interpreting and explaining

Period 3: The teacher presents the scientific classification (at least plants and animals). If possible the explanation should be based on or reflect the suggestions given by the students.
The teacher can hand out an additional info sheet.

Teaching aids: info sheet





				
not alive	animals	plants	fungi	bacteria

Big Idea No. 7: Worksheet 3: Classification of living creatures

Analyzing, interpreting and explaining

How do I adapt the task to my student's abilities?

- Additional task for fast students:
 - The creatures of the small groups can be dedicated to the groups that were found.
 - The creatures in the tables could be marked regarding the categories of the scientific categories
- Deepening: The creatures on the lists of small groups are assigned to the scientific categories.
- Other examples could be collected based on the scientific categories.

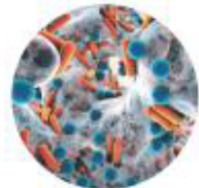
				
not alive	animals	plants	fungi	bacteria

Big Idea No. 7: Worksheet 3: Classification of living creatures

Analyzing, interpreting and explaining

Scientific research means not only to look at *WHAT* has changed. It is important to analyze this observation to find explanations which describe *WHY* this has happened. For this reason, the results have to be considered from different points of view and compared with previous predictions. This in turn creates new impulses that need to be integrated into existing concepts or the prediction has to be possibly re-examined.

Explorative learning also means that students are confronted with an explanatory approach that does not suit their previous knowledge. In this task they have to compare their prior knowledge and the categories of the task before with the scientific classification. Thus, they realize that a research process is not finished when you have collected data, but it is also central to analyze the results of the observation again. This process capability enables the children to further their knowledge of the phenomenon and perceive many different aspects.

				
not alive	animals	plants	fungi	bacteria

Big Idea No. 7: Worksheet 3: Classification of living creatures

Analyzing, interpreting and explaining

Hints for implementation

The aim of this task is to give students the opportunity to use the results of their research to enhance their understanding of scientific phenomena. It is not only enough to observe the results, but also to find explanations how and why this arises. For this reason, it is important to look at the predictions from different perspectives and to examine them in many ways in order to comprehend the phenomenon as comprehensively as possible and to question the starting idea. This process can be assisted with questions such as “Did you find any connection between ... and ...?”, “What do you think is the reason for ...?”.

Big Idea No. 7: Worksheet 3: Classification of living creatures

Analyzing, interpreting and explaining

Hints for implementation

How well am I doing as follows (already)?

- I give the students enough time to interpret and analyze their observations and results.
- I encourage the students to connect their observations with their knowledge through appropriate questions.
- I motivate the students to compare their observations with their ideas and the previous starting idea
- I adapt my assistance and explanations to the age, the abilities and experiences of the students.
- I use visual aids to clarify my explanations.
- I do not interfere the students research process by giving them any answers in advance.

Further ideas for other material:

- I encourage the students to test their predictions in different ways.

Big Idea No. 7: Worksheet 4: Alive or not?

Communicating, arguing, reflecting

Procedure:

The teacher introduces the following group assignment (which could be also discussed in class): „Check for the following "special cases" if they are alive or not and write down the reasons for your decision. Then try to classify them according to the groups scientists use“:

1. a fly
2. a flower bouquet
3. fire
4. an apple
5. an apple core
6. an orange
7. an orange with mildew
8. a dog
9. a robot dog

Big Idea No. 7: Worksheet 4: Alive or not?

Communicating, arguing, reflecting

During class discussion, it's sometimes not easy to determine if something is alive or not. Sometimes the classification into the scientific categories helps further. The aim of the task is not to find a clear solution. Instead of that it is important to activate the knowledge of the students and to consolidate in the discussion. Depending on the condition the „special cases“ can be alive or dead.

Afterwards, there can be a group work or the task is edited in the class discussion.

Teaching aids: It can help to show the "special cases" as illustrative material in the classroom. This makes it easier for the children to talk and discuss.

Educational objective: Reflection and discussion about untypical examples; Deepening, reflecting and recognizing boundaries of the definition of life.

Depending on the time frame and grade level, a selection of "special cases" should be made.

Big Idea No. 7: Worksheet 4: Alive or not?

Communicating, arguing, reflecting

Discussions have a central role in the research process. In this conversations, students are required to present their own point of view verbally (or in some other form, such as a presentation). As a result, they do not only convey information but also look at their results and current concepts from a different angle. On the one hand, this serves as a reflection of one's own knowledge, but also enables a common exchange of information and discussions in which explanations are negotiated, knowledge is built and initial prognoses are critically questioned.

The question "Alive or not?" offers the children a corresponding opportunity to talk because it is not easy (and sometimes not even possible) to transfer the given examples into the scientific categories. However, this is not the educational objective of the task. Rather, it serves to empower students to share ideas, to bring their views into the discussion and to reflect on their knowledge and observations. They also learn that they can not explain all facets of the phenomenon with their current knowledge. Therefore further investigations are needed. Thus, the general research process is also reflected in the key question "What could have been investigated?"

Alive
or not
alive?

Big Idea No. 7: Worksheet 4: Alive or not?

Communicating, arguing, reflecting

Hints for implementation

This task helps the students to make their thinking "visible" for themselves and others. By exchanging information with others about observations and results, on the one hand information is passed on, on the other hand new ideas and questions are generated, explanations are found together, the knowledge is built up and the initial prognosis and own perspectives are critically reflected. This can be supported of questions such as "Can you explain that a little more?", "How can you explain to the others what you did and what happened?" or "How can you show that (what evidence do you have) your conclusion is right?".

Big Idea No. 7: Worksheet 4: Alive or not?

Communicating, arguing, reflecting

Hints for implementation

How well am I doing as follows (already)?

- At the end of an activity I offer the students a time slot so that they can discuss their findings and explanations.
- I pay attention to a good class climate in which all answers and suggestions are appreciated.
- I encourage students to verbalize their thinking for deepening their knowledge.
- I accompany the communication of the students and am available as contact person.
- I encourage the students to reflect not only on their results, but also on the general research process (e.g. “What else could have been studied” or “What other measuring devices could have been used?”)

Further ideas for other material:

- I give the students the opportunity to present their results to their classmates.
- I provide different methods to the students, with whom they can describe and reflect their research process (e.g. notebooks)

Content

1. Introduction of the Big Idea 7 and what elementary school students are able to understand
2. Examples for the implementation of the contents from Big Idea 7
3. Structure of the material
 - Didactic procedure: Teacher's part
 - Didactic procedure: Worksheets for students

Structure of the material: Didactic procedure: Teacher's part

1. Theoretical part of the chapter:

General information, child-specific abilities, keywords

2. Scientific background for the teachers:

Deepening information to build a knowledge base for supporting the students

3. Methodological guidelines for the teachers:

- Overview table (duration, level of difficulty, age, needed materials, educational objective)
- Worksheets

Structure of the material: Didactic procedure: Teacher's part

1. Theoretical part of the chapter:

General information is given to provide an **overview** of the topic. Furthermore the content of the specific Big Idea is described with respect to the abilities of the children. It is discussed which aspects can already be understood by elementary school students. **Keywords** represent the main aspects of the topic.

2. Scientific background for the teachers:

The information of the theoretical input are deepened and explained in detail including the underlying scientific concepts and additional knowledge. So the teacher can build a knowledge base for supporting the students when they are working with the materials and to answer their questions.

Structure of the material: Didactic procedure: Teacher's part

3. Methodological guidelines for the teachers: Overview Table

Gives an overview of all the materials of the respective Big Idea. It contains the expected duration, level of difficulty, age, which materials are needed and illustrates the educational objective of the task. The table facilitates the planning of the lesson, helps to adjust the content to the children's abilities as well as tying on their experiences.

Structure of the material: Didactic procedure: Teacher's part

3. Methodological guidelines for the teachers: Worksheets

Here you will find the specific tasks of the topic prepared for the use in the classroom. Each task contains different parts. First an assignment/work order for the students is verbalised then paired with some instructions. This captures the process and helps the teacher to give necessary instructions and pedagogical guidance. In addition, the materials which are needed are described. Furthermore there are suggestions which make it possible to adapt the task to the individual needs of the children.

Structure of the material: Didactic procedure: Worksheets for students

In a second and separate part you will find the required teaching material in form of worksheets etc. They can be duplicated and printed as required.

What would Wynne Harlen say...?

- Describe the Big Idea No. 7 with your own words.
- Which aspects of the respective Big Idea are elementary school students already able to understand?
- Which important steps in the (scientific) cognitive process of the children are there/can be enabled?
- How are they integrated in the work with the material?

Continuative literature:

- Wynne, H. (2015) (Ed.). Working with big ideas of science education. Science Education Programme (SEP) of IAP
- Wynne, H. (2015). Teaching Science for understanding in elementary and middle school. Portsmouth: Heinemann

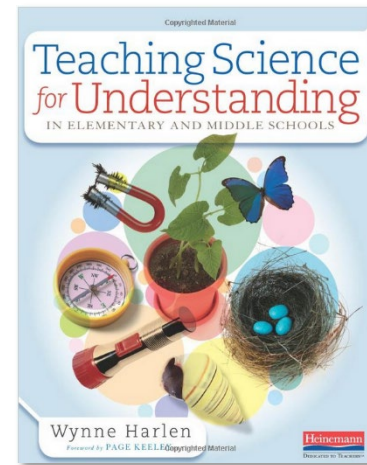

Further information:

- You can find further information and materials on our homepage <http://www.i-skype.com/> . There you will also find presentations concerning the Big Ideas No. 1,2,3,4,5,6,8,9 and 10.
- The methodical materials can be adapted in various ways to fit your class and the knowledge and interests of your students. So regarding the abilities of your students it may be useful to give additional information or to introduce other tasks and examples.



Erasmus+

Interactive Science
for Kids and Youngsters
i SKYPE

RAABE
*Spoločne ku kvalitnému
vzdelávaniu*



Have fun discovering the Big Ideas!



ZÁPADOČESKÁ
UNIVERZITA
V PLZNI



ZÁKLADNÍ ŠKOLA
J. GUTHA - JARKOVSKÉHO



LOUISEN LUND
LERNEN LEISTEN LEBEN



DIGITAL
CREATIVE

Project: I – S.K.Y.P.E. (Interactive Science for Kids and Youngsters in Primary Education)
This project has been funded with the support of the Erasmus+ Programme, K2 Action, Strategic Partnerships in School Education.
Project Agreement Number: 2016-1-SK01-KA201-022549

I-S.K.Y.P.E.

Interactive Science for Kids and Youngsters in Primary Education – Big Idea 9

„Genetic information is passed down from one generation of organisms to another“

The current publication reflects only the author’s view and neither the Slovak National Agency, nor the European Commission are responsible for any use that may be made of the information it contains.

What am I to expect?

This workshop wants to help you gain insight in Big Idea No. 9 “Genetic information is passed down from one generation of organisms to another” and wants to encourage you to introduce this basic phenomenon to scientific education in primary school. One aim is to use the existing knowledge and interests of the students and to empower them to encounter the subject matter self-directed. Sole knowledge acquisition is not central, but students should gain central (process) abilities for scientific research. In your role as a teacher, you are invited to reflect your own behaviour in the interaction with students and to adjust it adequately to the current stage of development. For this matter questions play a central role. The provided material does not only enable your students to expand their existing knowledge through new experiences and scientific process skills, but will also help you to re-discover your own role as a supportive coach and to investigate basic scientific phenomena together with your class.

To get an overview about how to design your lessons you can find a description, which aspects of the scientific phenomenon students in elementary schools are able to understand, on the following pages. Additionally, several tasks, which can be found in the materials, are explained theoretically. This shows which scientific process skills can be learned and developed by which of the tasks and how you can coach students by inspiring questions for example. Furthermore, the structure of the didactical material, which can also be downloaded, is described.

Content

- 1. Introduction of the Big Idea 9 and what elementary school students are able to understand**
- 2. Examples for the implementation of the contents from Big Idea 9**
- 3. Structure of the material**
 - Didactic procedure: Teacher's part
 - Didactic procedure: Worksheets for students

Big Idea No. 9

Genetic information is passed down from one generation of organisms to another

Genetic information in a cell is held in the chemical DNA. Genes determine the development and structure of organisms. In asexual reproduction all the genes in the offspring come from one parent. In sexual reproduction half of the genes come from each parent.

Big Idea No. 9

Genetic information is passed down from one generation of organisms to another

What are elementary school students able to understand?

Living things produce offspring of the same kind, but offspring are not identical with each other or with their parents. Plants and animals, including humans, resemble their parents in many features because information is passed from one generation to the next. Other features, such as skills and behaviour, are not passed on in the same way and have to be learned.

Content

1. Introduction of the Big Idea 9 and what elementary school students are able to understand

2. Examples for the implementation of the contents from Big Idea 9

3. Structure of the material

- Didactic procedure: Teacher's part
- Didactic procedure: Worksheets for students

Big Idea No. 9: Worksheet 1: Family photographs

Raising questions and planning inquiries

Procedure:

The choice of the photos should be given to the students as homework in advance.

„Please, bring photos of you and your family members (e.g. brother, sister, mother, father, ...) along. Choose images which you are able to recognize for sure.“

Depending on what is available, everything can be brought along: Pictures of parents, siblings, (great) grandparents etc. When all students have brought along their pictures, the following instruction can be given:

„Put all the pictures on the ground of the classroom and mix them up. Are you able to find out which family members belong to which student? What do you notice?“

The discussion will become fascinating if pictures of stepparents or stepsiblings are included. The teacher introduces the question: „What about similarities?“. However, one should not expect clear results.

Big Idea No. 9: Worksheet 1: Family photographs

Raising questions and planning inquiries

Teaching aids: pictures

Educational objective: *To illustrate the heredity of traits, to involve the children themselves, to become familiar with the trait similarities, to recognize the relationship between similarity and ancestry.*

How do I adapt the task to my student's abilities?

- The students can write down what they have noticed and discuss this in small groups or in class.
- Instead of printing the photos out they can be brought along digital. In this case the pictures can be projected at the wall and the students guess together which student the shown family member belongs to. Every student can bring along a different number of pictures.

Big Idea No. 9: Worksheet 1: Family photographs

Raising questions and planning inquiries

Previous knowledge is a key base in creating new knowledge. Students are primed individually for the (research) process through the activation of their own knowledge. Thus they are ready to integrate the new experience in their previous existing knowledge and to compare them. Hence resulting discrepancies lead the children to dig into new things.

This way motivation to think about a so far assumed aspect more thoroughly or to see it in a different perspective is created. Own ways of thinking or ideas will be „examined“ and it will be practised thereby to evolve questions, to be curious and to plan next steps. Conceptions about possible relationships or procedures are „thought up“.

The photos represent a frame of reference, which enables the students to combine the new topic with something familiar. Thus they form the basis for new experiences. By sharing and classifying the photos together in the classroom, the students find that some photos are easy to assign to the right child, which is challenging for others. But how do I assign the family photo to the right child? Here it is important to find the right criteria, to verify your own ideas and to obtain a first idea of the relationship between similarity and ancestry.



Big Idea No. 9: Worksheet 1: Family photographs

Raising questions and planning inquiries

Hints for implementation

This task has the purpose to activate the children's previous knowledge and to give them the opportunity to generate their own ideas. They in part need more or need less assistance through the teacher. This can be done by questions, like „What will happen, if...?“, „What in particular do you want to know?“ or „What exactly do we need to do in order to see/hear/experience this?“.

Big Idea No. 9: Worksheet 1: Family photographs

Raising questions and planning inquiries

Hints for implementation

How well am I doing as follows (already)?

- I encourage children to verbalize their ideas about relationships.
- I attach importance to an open-minded discussion atmosphere in class.
- I offer the opportunity to children to find out that there are different ideas concerning the same fact (for example through small group discussions or discussions with the whole class).
- I encourage children to write down their ideas/expectation or to draw them.
- I encourage children to think about what kind of relationships there are (“Which are the influencing factors?” or “Which features are going to change?”)

Further ideas for other material:

- I assist children to think about, what exactly they want to investigate and how they want to observe effects.
- I encourage children to generate first prognosis and predictions, which can be tested.

Big Idea No. 9: Worksheet 5: Tongue rolling



Gathering information

Procedure:

The students show their tongues to each other.

„How many of your classmates can roll their tongues?
Who can't do it?“

The results should be written down in the table.

	
<p>rolled tongue</p>	<p>not rolled tongue</p>
<p>number of students:</p>	<p>number of students:</p>

Teaching aids: worksheet

Educational objective: To show the dissemination of a specific trait within the class.

Big Idea No. 9: Worksheet 6: Tongue rolling in family

Gathering information

Can roll her/his tongue	Cannot roll her/his tongue

Procedure:

The teacher gives the students the following order: „Which member of your family can roll his/her tongue and who can't? Write it down!“. The answers should be entered in the table. In addition this order can be given as homework.

Teaching aids: worksheet

Educational objective: The task should explain the inheritance of a phenotypic trait.



How do I adapt the task to my student's abilities?

- If the children are familiar with it they could draw a family tree. Or you can introduce it as a new concept and the students could edit it at school.

Big Idea No. 9: Worksheet 5+6: Tongue rolling

Gathering information

Observation can be perceived as a basic tool for collecting data in the scientific process in order to collect data. What differentiates scientific observation, comparing to an everyday one, is that it is **more detailed** and **targeted**. These activities lead pupils to new discoveries in their environment and show them that it is still possible to learn something new and notice it differently. It is of great importance to guide pupils in the observation of this phenomena according to their stage of development and to create situations in which they have the opportunity to gain new abilities and build on their knowledge. Thus the more we find out, the more we are able to understand in the future.

	
rolled tongue	not rolled tongue
number of students:	number of students:

On the basis of the specifically formulated work assignment, the students are able to identify similarities and differences. Who can roll his/her tongue and who can not?

This way, information can be gathered that helps the students to understand the phenomenon in question, since tongue rolling is a specific feature that is distributed differently in each class. This knowledge can be recorded in a graphic, table, etc. and helps the children to align their observations with the existing knowledge or to use them for further thinking processes, so that they can develop their knowledge and skills.

Can roll her/his tongue	Cannot roll her/his tongue

Big Idea No. 9: Worksheet 5+6: Tongue rolling

Gathering information

Hints for implementation

In the phase of targeted observation or gathering information, the previous knowledge of the pupils is included on purpose. Processes like observing details, finding similarities and differences or as well patterns and relationships, are promoted by observation or data collection. The process can be implemented in terms of questions, like „What has happened, as...?“, „What differences do you notice between...?“. „What are you thinking...?“-questions might offer the opportunity to students to speak about speculations or even imperfect ideas, without having the „right“ answer ready.

Big Idea No. 9: Worksheet 5+6: Tongue rolling

Gathering information

Hints for implementation

How well am I doing as follows (already)?

- I encourage the students to recognize differences and similarities ("If you compare ... and ... what is different?", "What do you think is the same in different situations?").
- I give the students enough time for their observations.
- I offer students the opportunity to share their observations and ideas with others.

Further ideas for other material:

- I encourage the students to include other sources for seeking information (e.g. pc programs).
- I offer students opportunities to expand their observations (e.g. with magnifying glasses, a microscope, thermometers).

Big Idea No. 9: Worksheet 8: „Get-Up-Gene“

Analyzing, interpreting, explaining & communicating, arguing, reflecting

Procedure:

This game is called "Get-Up-Gene". The students are positioned in the classroom in the form of a family tree (genealogical tree), so that always two students represent the parents and one student the next generation. The first generation students each receive two marbles, either small or large. In the next step, each parent passes a marble to the next generation so that each child receives a marble from a parent. It goes on and on. It is important to remember the size of both marbles before the passing.

When all generations have been played through, everyone sits down on the floor. Now everyone can get up who had at least one big marble (the "Get-Up-Gene") in his/her hand. Then the following questions are asked: "What are you watching? Is a child standing when her/his parents aren't? "

Teaching aids: big and small marbles (depending on the number of children), lots of space

Big Idea No. 9: Worksheet 8: „Get-Up-Gene“

Analyzing, interpreting, explaining & communicating, arguing, reflecting

Example for the game "Get-Up-Gene":

- The first generation students start with two marbles.
- One of the marbles is handed to the next generation. In doing so many types of transmission are possible.

Yellow = big marble

Green = small marble

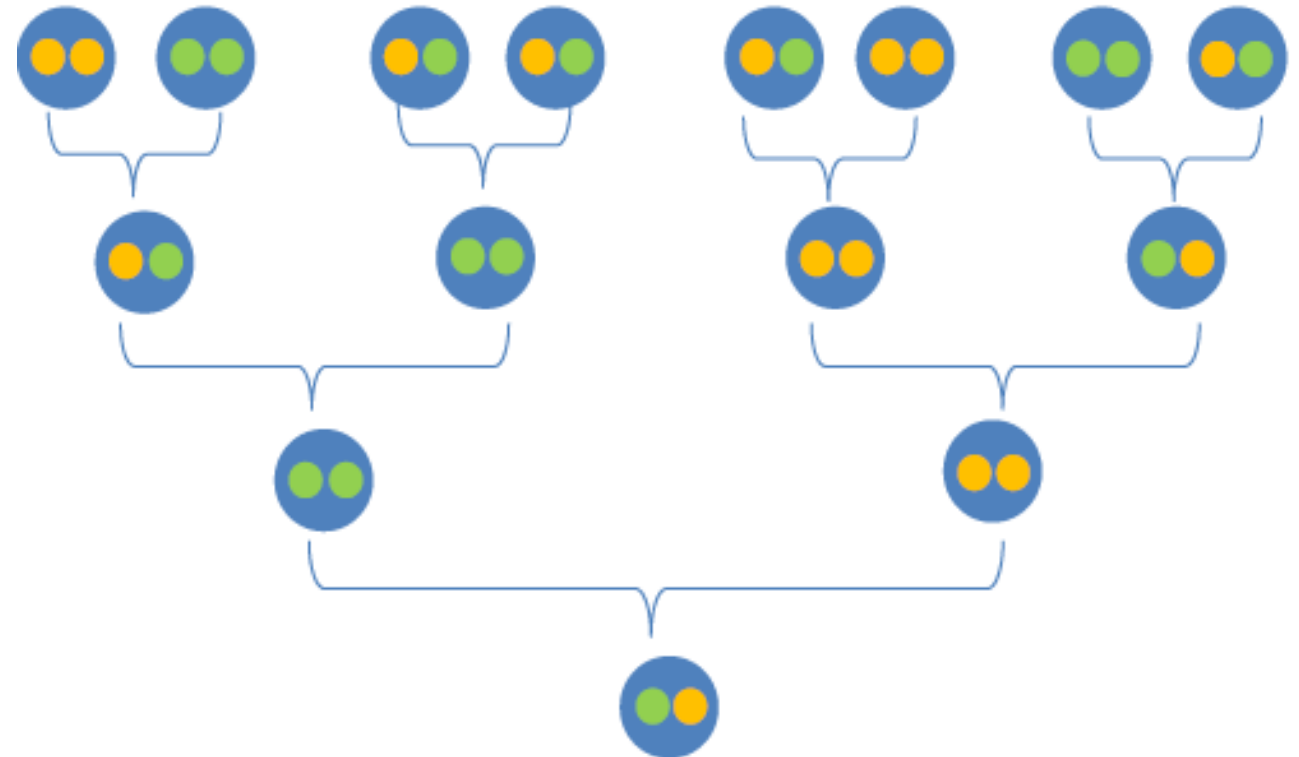

(Direction for transmission: from "above" to "below")

Big Idea No. 9: Worksheet 8: „Get-Up-Gene“

Analyzing, interpreting, explaining & communicating, arguing, reflecting

The “Get-Up-Gene” becomes especially interesting when children of the first generation hold different varieties of marbles in their hands. So at least one parent has two big marbles, at least one parent has two little marbles and at least one parent has a big and a small marble. This creates the most diverse genetic variants.

If a child stands at the end, then it has had a large marble in her/his hand. Thus, also a parent (at least one) has to stand. As an example, Mendel's Rule can be used.

***Educational objective:** To simulate and demonstrate human phenotypic inheritance.*

Big Idea No. 9: Worksheet 8: „Get-Up-Gene“

Analyzing, interpreting, explaining & communicating, arguing, reflecting

How can I adapt the job to the skills of my students?

- Instead of big and small marbles, you can also use two differently colored balls or similar objects.
- The children can also write down as a reminder which ball or materials they have received.

Big Idea No. 9: Worksheet 8: „Get-Up-Gene“

Analyzing, interpreting and explaining

Scientific research not only means to look at *WHAT* has changed. It is important to analyze this observation to find explanations which describe *WHY* this has happened. For this reason, the results have to be considered from different points of view and compared with previous predictions. This in turn creates new impulses that need to be integrated into existing concepts or the prediction has to be possibly re-examined.

After the children made their first experiences with features and their heredity transmission, it is crucial to look at them from another angle. In the "Get-Up-Gene", the children step out of the familiar family context, use their previous knowledge within the class community and try to re-examine their observations. In doing so, they note a certain regularity (that at least one parent always stands when their child is standing). On the one hand, this result agrees with the previous considerations that different generations (but not all) have some features in common. On the other hand, the previous approach is extended by the fact that features are always passed on from one generation to the next. This new impulse is incorporated into the existing concept of the phenomenon, thus expanding the child's knowledge.

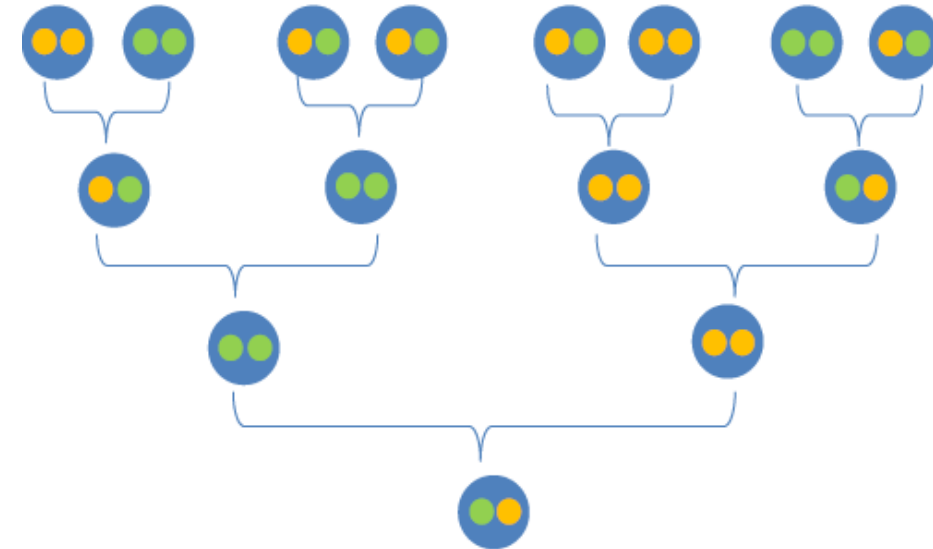

Big Idea No. 9: Worksheet 8: „Get-Up-Gene“

Analyzing, interpreting and explaining

Hints for implementation

The aim of this task is to give students the opportunity to use the results of their research to enhance their understanding of scientific phenomena. It is not enough to just observe the results, but also to find explanations how and why they arise. For this reason, it is important to look at the predictions from different perspectives and to examine them in many ways in order to comprehend the phenomenon as comprehensively as possible and to question the starting idea. This process can be assisted with questions such as "Did you find any connection between ... and ...?", "What do you think is the reason for ...?"

Big Idea No. 9: Worksheet 8: „Get-Up-Gene“

Analyzing, interpreting and explaining

Hints for implementation

How well am I doing as follows (already)?

- I give enough time to the students to interpret and analyze their observations and results.
- I encourage the students to connect their observations with their knowledge through appropriate questions.
- I motivate the students to compare their observations with their ideas and the previous starting idea.
- I adapt my assistance and explanations to the age, the abilities and experiences of the students.
- I use visual aids to clarify my explanations.
- I do not interfere with the students research process by giving them any answers in advance.
- I encourage the students to test their predictions in different ways.

Big Idea No. 9: Worksheet 8: „Get-Up-Gene“

Communicating, arguing, reflecting

Discussions have a central role in the research process. In this conversations, students are required to present their own point of view verbally (or in some other form, such as a presentation). As a result, they do not only convey information but also look at their results and current concepts from a different angle. On the one hand, this serves as a reflection of one's own knowledge, but also enables a common exchange of information and discussions in which explanations are negotiated, knowledge is built and initial prognoses are critically questioned.

In the “Get-Up-Gene”, all students are directly involved in the research process, as they themselves embody parents and/or children. These different points of view allow them to look at the process of inheritance of phenotypic traits from different perspectives, which they can exchange during the execution of the task. This gives the students the opportunity for discussing together. Then on the one hand information is exchanged, on the other hand, however, one's own point of view is supplemented by that of the other classmates. This allows the children to reflect on their own knowledge as well as the entire research process and to find explanations that help explain the phenomenon. The initial forecasts are critically scrutinized and checked for accuracy.

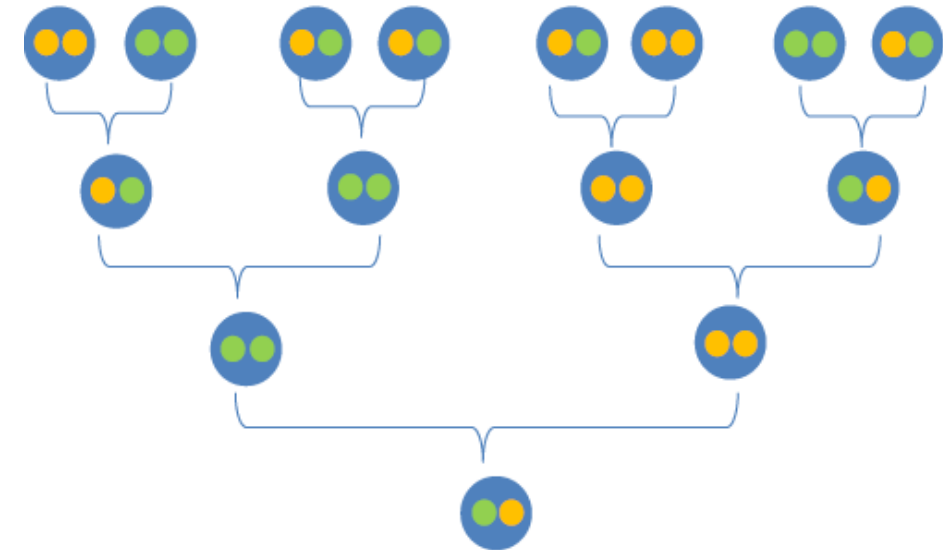

Big Idea No. 9: Worksheet 8: „Get-Up-Gene“

Communicating, arguing, reflecting

Hints for implementation

This task helps the students to make their thinking "visible" for themselves and others. By exchanging information with others about observations and results, on the one hand information is passed on, on the other hand new ideas and questions are generated, explanations are found together, the knowledge is built up and the initial prognosis and own perspectives are reflected critically. This can be supported by questions such as "Can you explain that a little more?" or "How can you show that (what evidence do you have that) your conclusion is right?".



Erasmus+



Big Idea No. 9: Worksheet 8: „Get-Up-Gene“

Communicating, arguing, reflecting

Hints for implementation

How well am I doing as follows (already)?

- At the end of an activity I offer the students a time slot so that they can discuss their findings and explanations.
- I pay attention to a good class climate in which all answers and suggestions are appreciated.
- I encourage students to verbalize their thinking for deepening their knowledge.
- I accompany the communication of the students and am available as a contact person.

Furhter ideas for other material:

- I give the students the opportunity to present their results to their classmates.
- I provide different methods to the students, with whom they can describe and reflect their research process (e.g. notebooks).
- I encourage the students to reflect not only on their results, but also on the general research process (e.g. “What else could have been studied?” or “What other measuring devices could have been used?”).



Content

1. Introduction of the Big Idea 9 and what elementary school students are able to understand
2. Examples for the implementation of the contents from Big Idea 9
3. Structure of the material
 - Didactic procedure: Teacher's part
 - Didactic procedure: Worksheets for students

Structure of the material: Didactic procedure: Teacher's part

1. Theoretical part of the chapter:

General information, child-specific abilities, keywords

2. Scientific background for the teachers:

Deepening information to build a knowledge base for supporting the students

3. Methodological guidelines for the teachers:

- Overview table (duration, level of difficulty, age, needed materials, educational objective)
- Worksheets

Structure of the material: Didactic procedure: Teacher's part

1. Theoretical part of the chapter:

General information is given to provide an **overview** of the topic. Furthermore the content of the specific Big Idea is described with respect to the abilities of the children. It is discussed which aspects can already be understood by elementary school students. **Keywords** represent the main aspects of the topic.

2. Scientific background for the teachers:

The information of the theoretical input are deepened and explained in detail including the underlying scientific concepts and additional knowledge. So the teacher can build a knowledge base for supporting the students when they are working with the materials and to answer their questions.

Structure of the material: Didactic procedure: Teacher's part

3. Methodological guidelines for the teachers: Overview Table

Gives an overview of all the materials of the respective Big Idea. It contains the expected duration, level of difficulty, age, which materials are needed and illustrates the educational objective of the task. The table facilitates the planning of the lesson, helps to adjust the content to the children's abilities as well as tying on their experiences.

Structure of the material: Didactic procedure: Teacher's part

3. Methodological guidelines for the teachers: Worksheets

Here you will find the specific tasks of the topic prepared for the use in the classroom. Each task contains different parts. First an assignment/work order for the students is verbalised then paired with some instructions. This captures the process and helps the teacher to give necessary instructions and pedagogical guidance. In addition, the materials which are needed are described. Furthermore there are suggestions which make it possible to adapt the task to the individual needs of the children.

Structure of the material: Didactic procedure: Worksheets for students

In a second and separate part you will find the required teaching material in form of worksheets etc. They can be duplicated and printed as required.

What would Wynne Harlen say...?

- Describe the Big Idea No. 9 with your own words.
- Which aspects of the respective Big Idea are elementary school students already able to understand?
- Which important steps in the (scientific) cognitive process of the children are there/can be enabled?
- How are they integrated in the work with the material?

Continuative literature:

- Wynne, H. (2015) (Ed.). Working with big ideas of science education. Science Education Programme (SEP) of IAP
- Wynne, H. (2015). Teaching Science for understanding in elementary and middle school. Portsmouth: Heinemann

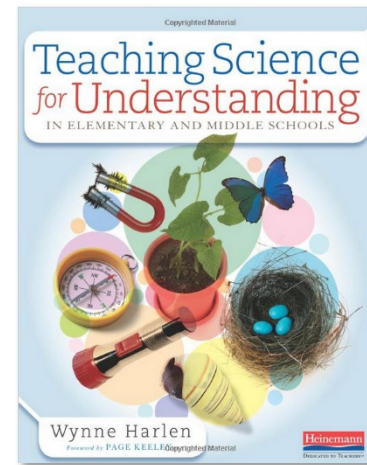

Further information:

- You can find further information and materials on our homepage <http://www.i-skype.com/> . There you will also find presentations concerning the Big Ideas No. 1,2,3,4,5,6,7,8 and 10.
- The methodical materials can be adapted in various ways to fit your class and the knowledge and interests of your students. So regarding the abilities of your students it may be useful to give additional information or to introduce other tasks and examples.



Erasmus+

Interactive Science
for Kids and Youngsters
i SKYPE

RAABE
*Spoločne ku kvalitnému
vzdelávaniu*



Have fun discovering the Big Ideas!



ZÁPADOČESKÁ
UNIVERZITA
V PLZNI



ZÁKLADNÍ ŠKOLA
J. GUTHA - JARKOVSKÉHO



LOUISEN LUND
LERNEN LEISTEN LEBEN



DIGITAL
CREATIVE

Project: I – S.K.Y.P.E. (Interactive Science for Kids and Youngsters in Primary Education)

This project has been funded with the support of the Erasmus+ Programme, K2 Action, Strategic Partnerships in School Education.

Project Agreement Number: 2016-1-SK01-KA201-022549

I-S.K.Y.P.E.

Interactive Science for Kids and Youngsters in Primary Education

Workshop for Teachers – Theoretical Overview

The current publication reflects only the author's view and neither the Slovak National Agency, nor the European Commission are responsible for any use that may be made of the information it contains.

Content

1. Teaching science for understanding

- Main Idea: Why teaching science? What science should we teach?
- Big Ideas of Science
- How to develop Big Ideas

2. Model of learning through inquiry (Wynne Harlen)

3. Science process skills

Content

1. Teaching science for understanding

- Main Idea: Why teaching science? What science should we teach?
- Big Ideas of Science
- How to develop Big Ideas

2. Model of learning through inquiry (Wynne Harlen)

3. Science process skills

Main Idea: Why teaching science? What science should we teach?

Education should not only generate knowledge, but also prepare the students for life. Thus it has to develop children's natural way of thinking, based on rational reasoning, because the product of the thinking process is used for understanding what happens in the world around them.

But this is contrary to the science education in schools nowadays. Students complain about memorizing facts and formulas and teachers still feel the absence of confidence in teaching science related subjects because of the lack of resources and ideas on how to motivate learners, as well as specifics of the curriculum and syllabus of these subjects.

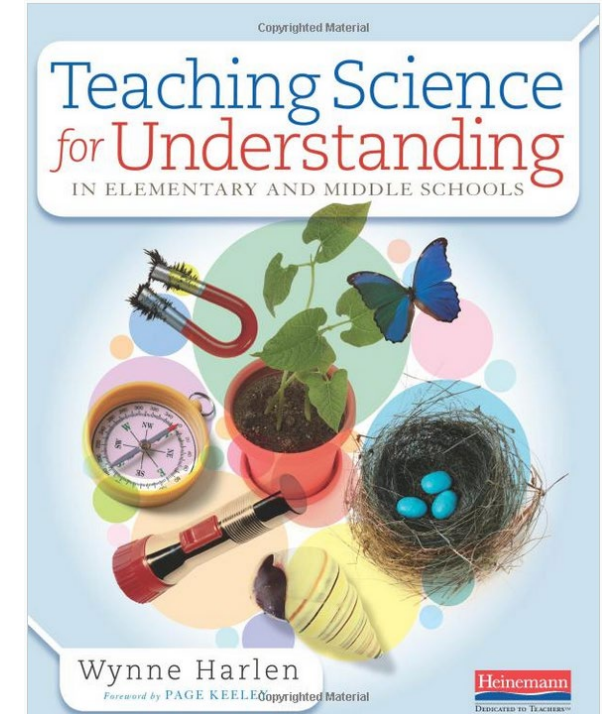

Main Idea: Why teaching science? What science should we teach?

Scientific knowledge:
concepts, theories etc.



Scientific process skills: raising
questions, observation, collecting
data etc.

While thinking about suitable educational instructions for primary science education, it is important to realize, that natural sciences are specific not only by its content (**scientific knowledge**), but also by the process of how the scientific knowledge is created (**scientific process skills**)!

What do you think?: What skills and competencies should students acquire in science education?



Science Education – Skills and competencies

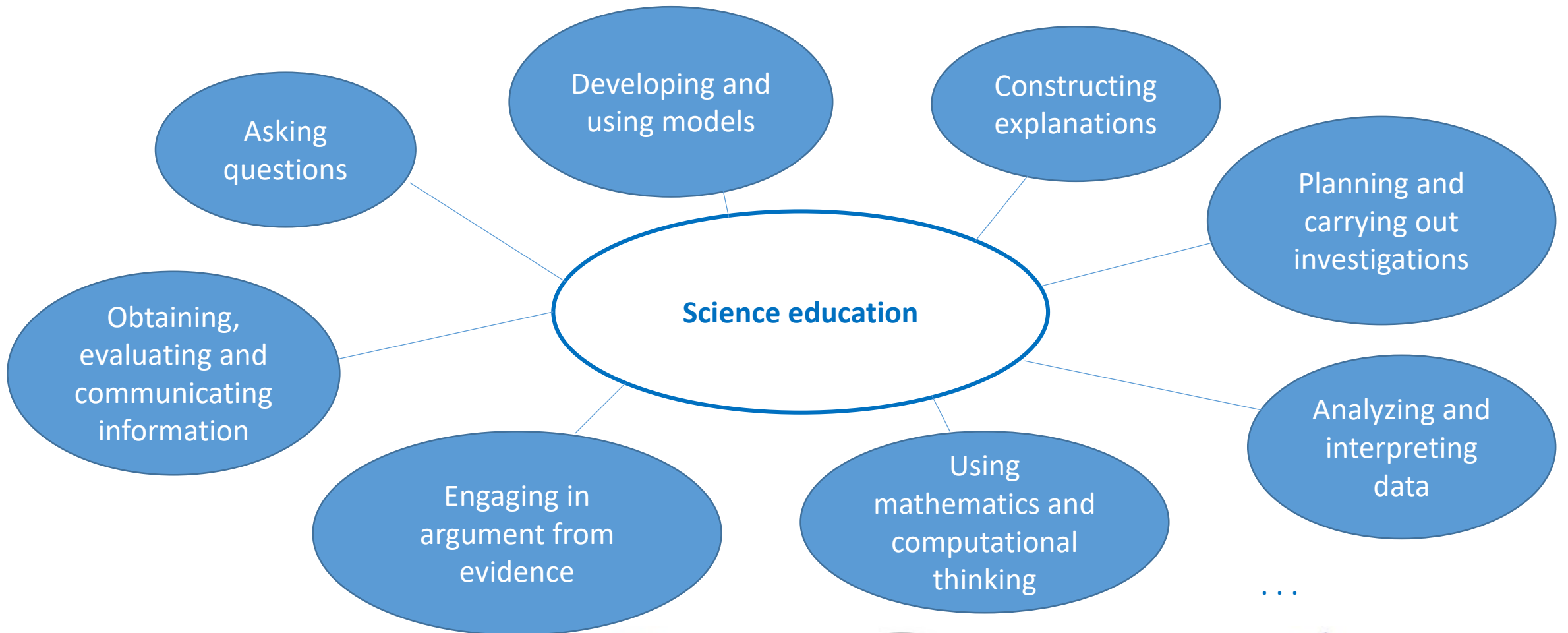

Main idea: Why teaching science? What science should we teach?

Accordingly, there are some important features to consider regarding effective science teaching:

- **Experiences and interests of the students are focused:**

The teacher has to introduce assignments etc. that are founded by the interests of the students. Then they are engaged and motivated to answer the questions and problems they have raised through researching. Thus the teacher enables them to develop ideas and skills based on their experiences and topics.

- **Attitude:**

The interests of the students should be perceived and taken seriously. Furthermore it is important, that the teacher knows the students very well, because then she/he can take into account their stage of development, plan the lessons according to their competencies and give the right assistance (scaffolding). In addition, it is important which attitude the teacher himself or herself has to science. He must have the confidence to teach science related subjects and notice the importance of science knowledge and process skills for the overall development of the students.

Main idea: Why teaching science? What science should we teach?

- **Developing a climate of learning:**

The activities happening in the classroom take place within the social climate. The teacher and the other adults have an important role helping students to create their knowledge, because they influence each other in their ability and willingness to learn. It is important that they respect each other and the different ideas and interests are valued and taken seriously. Thus a classroom climate in which the students feel safe to express their ideas could be established and lays the foundation for continued and motivated learning.

Content

1. Teaching science for understanding

- Main Idea: Why teaching science? What science should we teach?
- [Big Ideas of Science](#)
- How to develop Big Ideas

2. Model of learning through inquiry (Wynne Harlen)

3. Science process skills

Main idea: Which concept suits best with these considerations?

A very suitable concept we can use for appropriate development of scientific literacy is the concept of **Big Ideas in Science Education** (Prof. Wynne Harlen, University Bristol), because it clearly reflects most of the actual problems of primary science education. It is aimed not only on functional development of fundamental ideas of science, but it deals also with scientific processes and the whole nature of science. The scientific content is developed together with the scientific process skills using inductive way of teaching. Overall the students obtain an appropriate idea about the nature of science.



Main idea: Which concept suits best with these considerations?

The concept identifies **14 ideas** to be developed during elementary science education: **10 fundamental Big Ideas of Science** and additional **4 Big Ideas about Science**.

The ideas are...

... so big that they explain many different phenomena.

... still so comprehensible that even elementary school students can approach them.

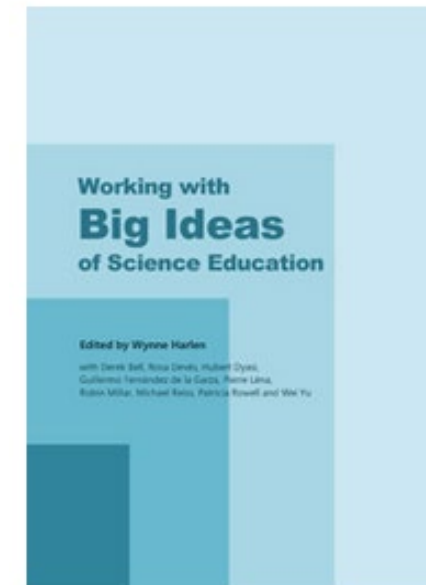

Note: In contrast isolated facts do not contribute extensive scientific knowledge!

Big Ideas of Science Education according to Wynne Harlen 1

1. All matter in the universe is made of very small particles

Atoms are the building blocks of all matter, living and non-living.

2. Objects can effect other objects at a distance

All objects have an effect on other objects without being in contact with them.

3. Changing the movement of an object requires a net force to be acting on it

A force acting on an object is not seen directly but is detected by its effect on the object's motion or shape. If an object is not moving the forces acting on it are equal in size and opposite.

4. The total amount of energy in the universe is always the same but can be transferred from one energy store to another during an event

Many processes or events involve changes and require an energy source to make them happen. Energy can be transferred from one body or group of bodies to another in various ways.

Big Ideas of Science Education according to Wynne Harlen 2

5. **The composition of the earth and its atmosphere and the processes occurring within them shape the earth's surface and its climate**
Radiation from the sun heats the Earth's surface and causes convection currents in the air and oceans, creating climates. The movement of the plates form the Earth's crust and creates volcanoes and earthquakes.
6. **Our solar system is a very small part of one of billions of galaxies in the universe**
Day and night and the seasons are explained by the orientation and rotation of the earth as it moves round the sun.
7. **Organisms are organized on a cellular basis and have finite life span**
All organisms are constituted of one or more cells. All the basic functions of life are the result of what happens inside the cells which make up an organism. Growth is the result of multiple cell division.
8. **Organisms require a supply of energy and materials for which they often depend on, or compete with, other organisms**
Food provides materials and energy for organisms to carry out the basic functions of life and to grow.

Big Ideas of Science Education according to Wynne Harlen 3

9. **Genetic information is passed down from one generation of organisms to another**
Genetic information in a cell is held in the chemical DNA. Genes determine the development and structure of organisms.
10. **The diversity of organisms, living and extinct, is the result of evolution**
All life today is directly descended from a universal common ancestor that was a simple one-celled organism. Over countless generations changes resulting from natural diversity within a species lead to the selection of those individuals best suited to survive under certain conditions.

Big Ideas about Science according to Wynne Harlen

- 1. Science is about finding the cause or cause of phenomena in the natural world**
The diversity of natural phenomena requires a diversity of methods and instruments to generate and test scientific explanations.
- 2. Scientific explanations, theories and models are those that best fit the evidence available at a particular time**
A scientific theory or model representing relationships between variables of a natural phenomenon must fit the observations available at the time and lead to predictions that can be tested.
- 3. The knowledge produced by science is used in engineering and technologies to create products to serve human ends**
The use of scientific ideas in technologies has made changes in many aspects of human activity. Advances in technologies enable further scientific activity; in turn this increases understanding of the natural world.
- 4. Applications of science often have ethical, social, economic and political implications**
Ethical and moral judgments may be needed, based on such consideration as justice or equity, human safety and impacts on people and the environment.

Content

1. Teaching science for understanding

- Main Idea: Why teaching science? What science should we teach?
- Big Ideas of Science
- How to develop Big Ideas

2. Model of learning through inquiry (Wynne Harlen)

3. Science process skills

How to develop Big Ideas: from small to big ideas

The life of the students is full of experiences which can not be explained by their previous knowledge. Their thinking and their scientific understanding are still evolving. Typically students are keen on understanding phenomena, but are not yet able to grasp all the necessary perspectives and to consider them in their deliberations or to understand different relationships and interactions between individual phenomena.

Therefore, it is necessary for students to observe and study these phenomena continuously and in-depth. Thus they are able to understand the mutual aspects of them and the small ideas (which are explaining particle phenomena) are further linked together using induction – from small the bigger ideas are created.

This bigger idea is more functional and helps to understand natural phenomena better. Therefore students should be equipped with a huge amount of small ideas, because they are essential for the creation of ideas which are more operational and general.

How to develop Big Ideas: from small to big ideas

This process in which small ideas are shifted to bigger ones could be compared to the process of solving a puzzle. The small pieces have to be observed and examined to look how they fit together. Thus with the small particular pieces (for example with the same color) a bigger one could be created which in turn is a small part of the whole picture. Therefore it is necessary to observe and compare a lot for creating the small parts of the puzzle.



https://www.magiccityweekend.com/cure-holiday-boredom/puzzle-1179870_640/

Borders of the small parts indicate how they are going to be put together – if we observe them well.

So it is similar to the process using induction, because the small ideas are put together to create a complex picture of the whole phenomenon.

How to develop Big Ideas: from small to big ideas

The special thing about this concept is, that the big idea is always present. It sets the framework and the structure in which the students could move and examine the whole phenomenon. Thus it is important that the teacher always have the big idea in mind, because he or she has to guide the students if they run out of the frame but also has to encourage them to move within the framework for improving their knowledge and skills by learning through inquiry.

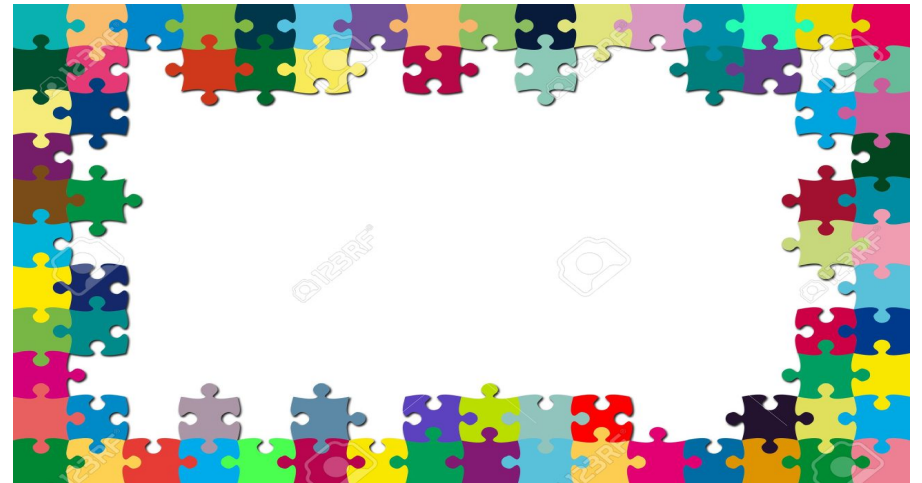

https://de.123rf.com/photo_8384195_eine-mehrfarbige-puzzle-rahmen-mit-einem-wei%C3%9Fen-hintergrund.html

How to develop Big Ideas: from scientific content-related ideas to scientific process-related ideas

The entire process is raised by some experience the student makes in interacting with his environment, creating questions or problems which need to be answered. Thus the starting point of every activity is in proposition of an appropriate research (inquiry) question. To find an answer, these content-related questions must be transferred in process-related questions, because then the problem can be examined by learning through inquiry.

The role of the teacher is, to lead the students to find the answer, using inquiry and introduction as a part of it. All the proposed teaching instructions should lead the students to their inquiry effort. Using this approach, science process skills can be developed.

The students feel their own competence to find answers and further they are more willing to deal with more and more difficult tasks. Development of science process skills equips students with a tool for changing small ideas to bigger ones, because they are moving from description to understanding the nature.

How to develop Big Ideas: grasping nature of science using inductive way of teaching

The cognitive key tool the students use to develop their ideas of and about science can be named as scientific skill and could further described as follows: scientific capability concerned with gathering and using evidence for proving or refuting prior understanding. This complex skill can be split into specific skills and further can be better understood in connection with effort of scientific literacy development. The activities proposed in the I-S.K.Y.P.E. project are designed to highlight development of the mentioned skills.

Content

1. Teaching science for understanding

- Main Idea: Why teaching science? What science should we teach?
- Big Ideas of Science
- How to develop Big Ideas

2. Model of learning through inquiry (Wynne Harlen)

3. Science process skills

Model of learning through inquiry

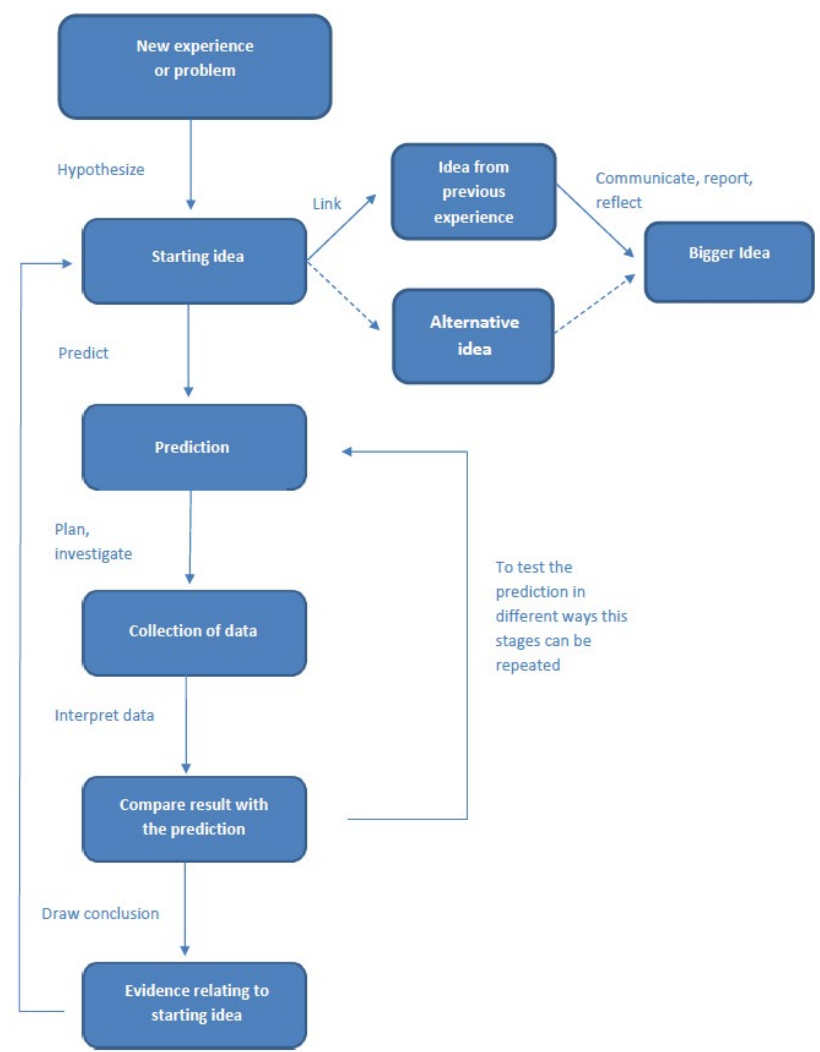

Model of learning through inquiry: general information

The theoretical basis of the concept of the big ideas is, that the students should learn through inquiry. That means they shouldn't only create knowledge by memorizing facts and by mere describing *what* they see. They should understand the underlying mechanisms also. The aim is that students understand *why* objects have certain characteristics and show certain behaviours (e.g. float or fly).

To find out about the „*why*“, the underlying mechanisms, students need several (science process) skills, like hypothesizing, planning, observing, which organize the process of learning through inquiry. The term inquiry itself refers to seeking information to answer questions which is the general part of scientific research. Thus scientific inquiry applies to questions of the (natural and made) world around us and leads to the understanding of scientific phenomena.

The model of learning through inquiry pictured the individual steps of a scientific research process. It can be adapted to the level of development of the students, so you don't have to start from the beginning, but could start at the point in the research process where the students are currently standing.

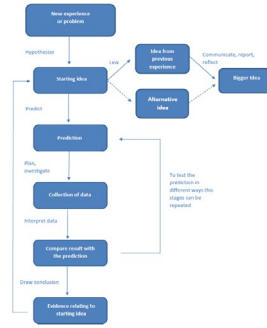

Model of learning through inquiry: general information

“Developing scientific inquiry skills is central to the construction of ideas that enable understanding. This is an important reason for helping students develop their inquiry skills and use them with appropriate rigor. Another reason, of course, is that by reflecting on their learning they develop skills needed for making sense of new experiences throughout their lives.” (Harlen, 2015)

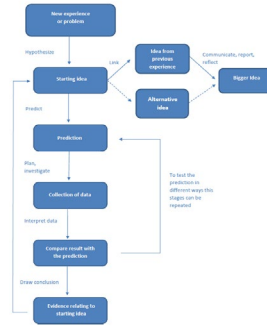

To illustrate the process of scientific research, the individual steps of the model of learning through inquiry are described subsequent.

Model of learning through inquiry: Stages

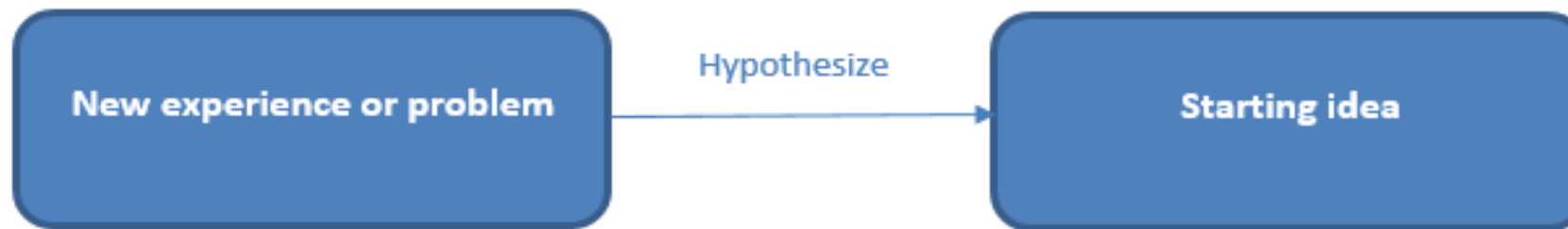

The process starts with a new experience or a problem that raises a question, because it couldn't be explained with the current knowledge of the students. Thus the experience or the problem has to be compared with the own experiences to identify investigable questions and hypotheses. Hence a starting idea, which forms the basis of the scientific research process, has been created.

Model of learning through inquiry: Stages

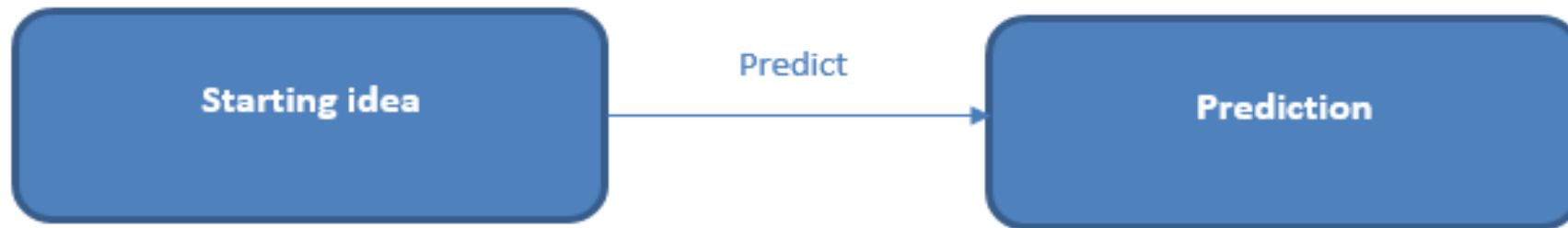

Within the starting idea there are several hypotheses to be tested. One of these has to be examined in more detail. So the students have to make a prediction based on this existing idea, which could be inquired through inductive learning.

Model of learning through inquiry: Stages

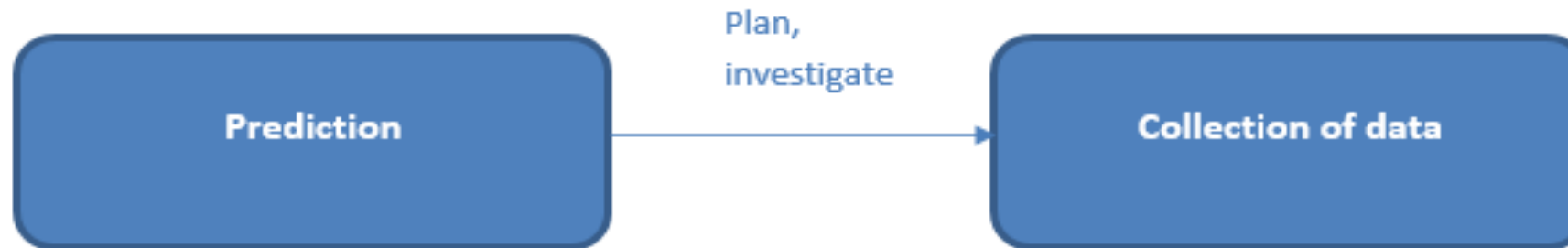

In the next step an investigation is conducted to see whether there is evidence to support the prediction. Therefore the students have to plan exactly which research activities are carried out to gather appropriate information and collect data. This process has to be adapted to their scientific process skills and their scientific knowledge. It is the responsibility of the teacher to encourage students to reflect on the links between the respective results and give them sufficient time to investigate the prediction. That enables the students not only to generate more scientific knowledge, but also to enhance their scientific process skills.

Model of learning through inquiry: Stages



It is quite often, that scientific education is finished with the collection of data. But it is necessary that the students compare the collected data and the results with the predictions they have made. Then they will find out, if the results can explain the prediction or if they have to repeat the process and test the prediction in different ways.

Model of learning through inquiry: Stages

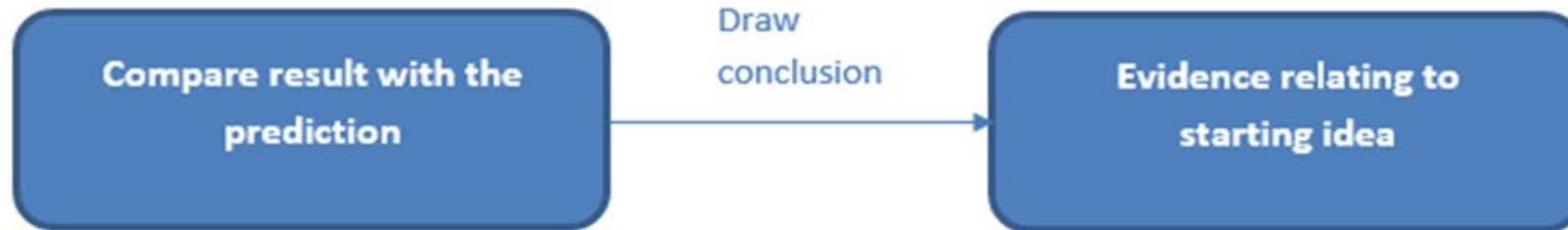

If the prediction was suitable, the conclusions from the tests are used for evidence relating to the starting idea. The students have to find out whether or not the starting idea provides a good explanation of the new experience or if it could be a solution to the initial problem. In this stage it can be emphasized that the students learn/are able to argue for their conclusion using evidence.

Model of learning through inquiry: Stages

If the evidence shows that the starting idea gives a good explanation, it can be linked with the previous experience. Therefore it is helpful, when the students communicate and report their research process. Then they are able to take a different perspective, reflect the process and relate it to the previous knowledge, so that it can be extended. So a small idea or a specific problem becomes a “bigger” (but not confirmed) idea by learning through inquiry. This bigger idea relates to several situations and could be generalized to a set of phenomena. If the starting idea hasn't provided appropriate explanations an alternative idea must be found and investigated.

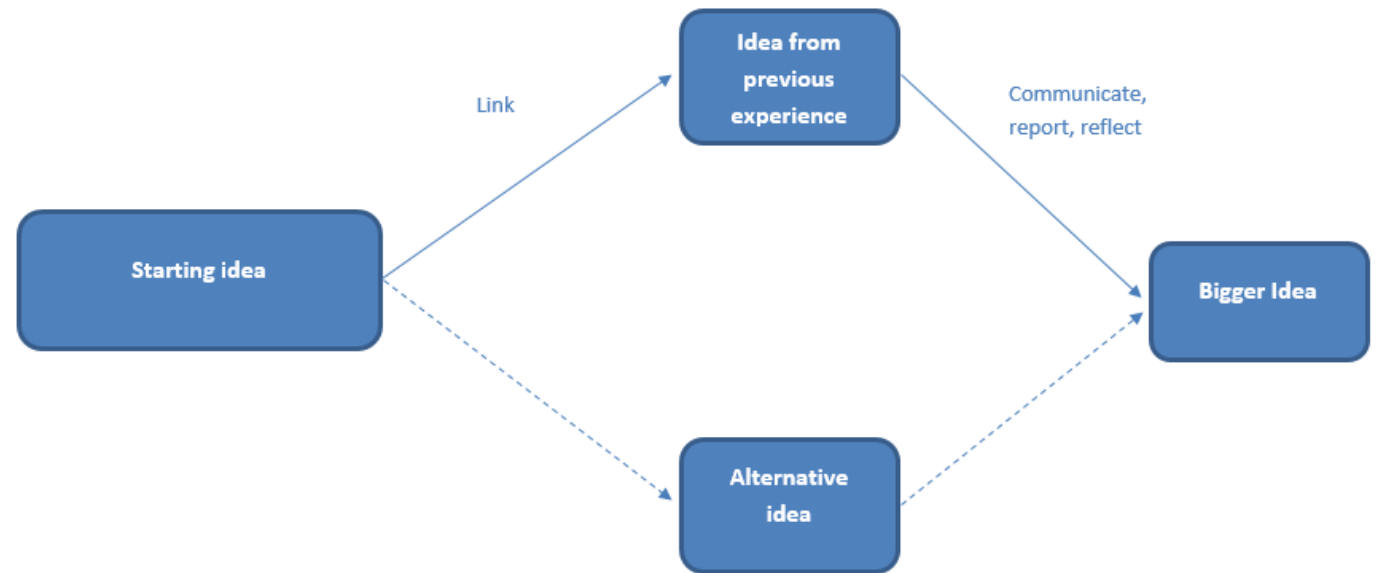

Content

1. Teaching science for understanding

- Main Idea: Why teaching science? What science should we teach?
- Big Ideas of Science
- How to develop Big Ideas

2. Model of learning through inquiry (Wynne Harlen)

3. Science process skills

Science process skills

During the described process of research-based learning, not only knowledge is generated, but also many scientific process capabilities are claimed, practiced and further developed. These skills are clarified in the following slides.

It is not only important to know, that these skills are promoted by learning through inquiry, but it is also important how the teacher can encourage the students, give hints and guide by asking the right questions.

In doing so, the teacher can use several questions which are adapted to the state of development of the students and the research process. These questions enable students to verbalize their thinking and ideas, encouraging the use of research skills, strengthening collaboration and interaction, and helping students to reflect their actions.

Appropriate questions regarding the respective activity or to encourage the specific capabilities can be found below in the blue boxes.

Science process skills: Raising questions and planning inquiries

At the beginning of the research it is important to activate the children's prior knowledge and to let them develop their ideas. In this way, the interests and experiences of the students are focused and taken up again within the process so that the students can identify themselves with the prior question. Thus it is important that the students find hypotheses and make initial predictions which can be investigated. This investigation has to be planned. The role of the teacher is to encourage and support the students according to their interests and stage of development.

Teachers' questions to encourage student's questioning and planning:

- What would you like to know about...?
- What do you think will happen if your idea is correct?
- What do you think will happen if ... or when ...?
- What do you think will make this go ...?
- What will you need to do to find out ...?
- How will you make it fair?

Science process skills: Gathering information

There are many ways to gather information or to collect data. In primary school observation is most popular. In doing so, processes such as observing details, finding similarities and differences or patterns and relationships are promoted. The role of the teacher is to give the students the opportunity to observe and to encourage and support them according to their needs. The students can be given the opportunity to work with instruments such as a microscope or to use pictures and models. Furthermore all sorts of tables, diagrams, graphs, charts, figures e.g. are suitable for the observation. Besides additional sources, for example a computer, help the students to gather information. In summary, these aspects enable the students to observe detailed and targeted. That is important, because only in this way reliable data can be collected to show if the ideas and predictions are correct and deliver results that can amplify existing knowledge.

Teachers' questions to encourage skills for gathering information by observing:

- What do you notice that is the same about these ...?
- What differences do you notice between the ... of the same kind?
- What differences do you see when you look through the lens?
- How much longer (heavier, etc.) is this than ...?
- What did you notice about places where you found the most ...?
- What more can you find out about ... from the books and the internet?

Science process skills: Analyzing, interpreting and explaining

An important part of the scientific research process is to give students the opportunity to use the results of their research to enhance their understanding of scientific phenomena. Therefore it is not only necessary to observe a transformation, but also to find explanations why this arises. For this reason, it is important to look at the predictions taken from different perspectives and to examine them in many ways in order to grasp the phenomenon as comprehensively as possible and to compare the results with the starting idea. The role of the teacher is not to give the students complete answers, but instead to encourage them to test their predictions many times and connect their observations with their prior knowledge. In summary, these process skills enable the students to analyze the results precisely and to discover more and more facets (and their interactions) of the phenomenon.

Teachers' questions to support analysis and interpretation:

- How did what you found out compare with what you expected?
- Did you find any connection between ... and ...?
- What did you find makes a difference to how fast ... how far ... how many ...?
- What do you think is the reason for ...?
- What would you expect if ... ?
- Would ... or ... explain better, what you found?

Science process skills: Communicating, arguing, reflecting

These skills enable students to make their thinking "visible" to themselves and others. By exchanging information with or present results to their classmates the observations and the whole research process is reflected. During the communication with others, students are challenged to verbalized their thinking and to take a different perspective. Thus they revisit their findings from this perspective. Therefore on the one hand information is passed on, but on the other hand new ideas and questions are generated, explanations are found together, (new) knowledge is built up (because you get to know a different perspective from your own) and the own view is considered critically. The role of the teacher is to encourage students to verbalize their thinking, to communicate with each other and to provide them with appropriate materials to present their findings to the others.

Teachers' questions to support communication skills:

- Can you explain that a little more?
- How are you going to keep a record of what you do and find?
- What kind of chart/graph/drawing do you think is the best way to show the results?
- How can you explain to the others what you did and what happened?
- How can you show that (what evidence do you have that) your conclusion is right?
- What other conclusions can you draw from your results?

Continuative literature:

- Wynne, H. (2015) (Ed.). Working with big ideas of science education. Science Education Programme (SEP) of IAP
- Wynne, H. (2015). Teaching Science for understanding in elementary and middle school. Portsmouth: Heinemann

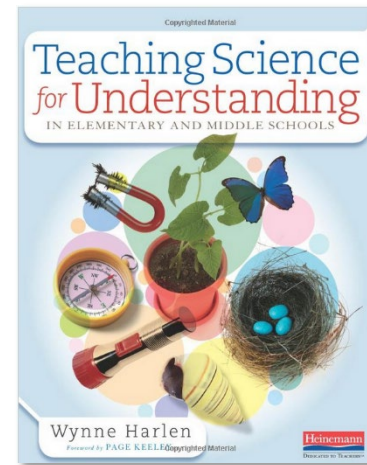

Project: I – S.K.Y.P.E. (Interactive Science for Kids and Youngsters in Primary Education)
This project has been funded with the support of the Erasmus+ Programme, K2 Action, Strategic Partnerships in School Education.
Project Agreement Number: 2016-1-SK01-KA201-022549

I-S.K.Y.P.E.

Interactive Science for Kids and Youngsters in Primary Education

Workshop for teacher

The current publication reflects only the author's view and neither the Slovak National Agency, nor the European Commission are responsible for any use that may be made of the information it contains.

Content

1. Education leads to an understanding of the science

- Formulation of main ideas: Why teach science at all? What science should we teach?
- Big Ideas of Science Education
- Didactic procedures for the development of scientific ideas

2. Model of learning through inquiry (Wynne Harlen)

3. Science process skills

4. Activities examples

Content

1. Education leads to an understanding of the science

- Formulation of main ideas: Why teach science at all? What science should we teach?
- Big Ideas of Science Education
- Didactic procedures for the development of scientific ideas

2. Model of learning through inquiry (Wynne Harlen)

3. Science process skills

4. Activities examples

Formulation of main ideas:

Why teach science at all? What science should we teach?

Education should not only generate knowledge, but also prepare the students for life. Thus it has to develop children's natural way of thinking, based on rational reasoning, because the product of the thinking process is used for understanding what happens in the world around them.

But this is contrary to the science education in schools nowadays. Students complain about memorizing facts and formulas and teachers still feel the absence of confidence in teaching science related subjects because of the lack of resources and ideas on how to motivate learners, as well as specifics of the curriculum and syllabus of these subjects.

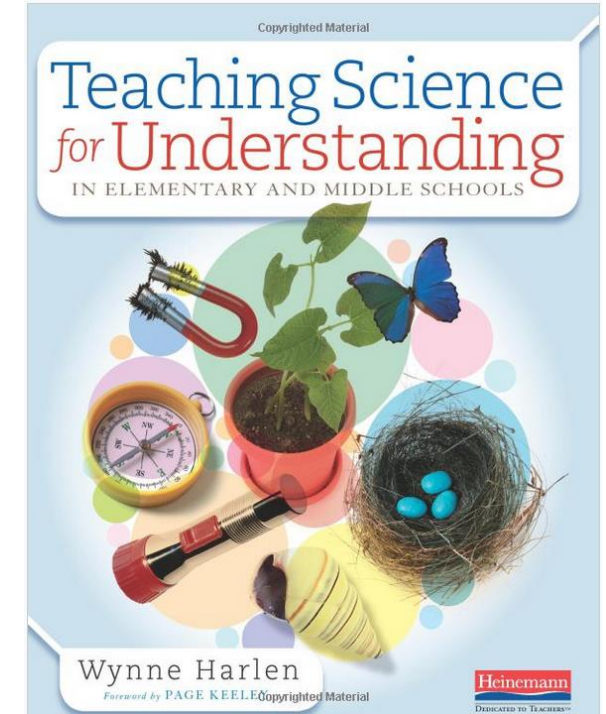

Formulation of main ideas:

Why teach science at all? What science should we teach?

Scientific knowledge:
concepts, theories etc.



Scientific process skills: raising questions, observation, collecting data etc.

While thinking about suitable educational instructions for primary science education, it is important to realize, that natural sciences are specific not only by its content (**scientific knowledge**), but also by the process of how the scientific knowledge is created (**scientific process skills**)!

What do you think?
**What skills and competences should pupils
acquire during science education?**



Science education – competences and skills

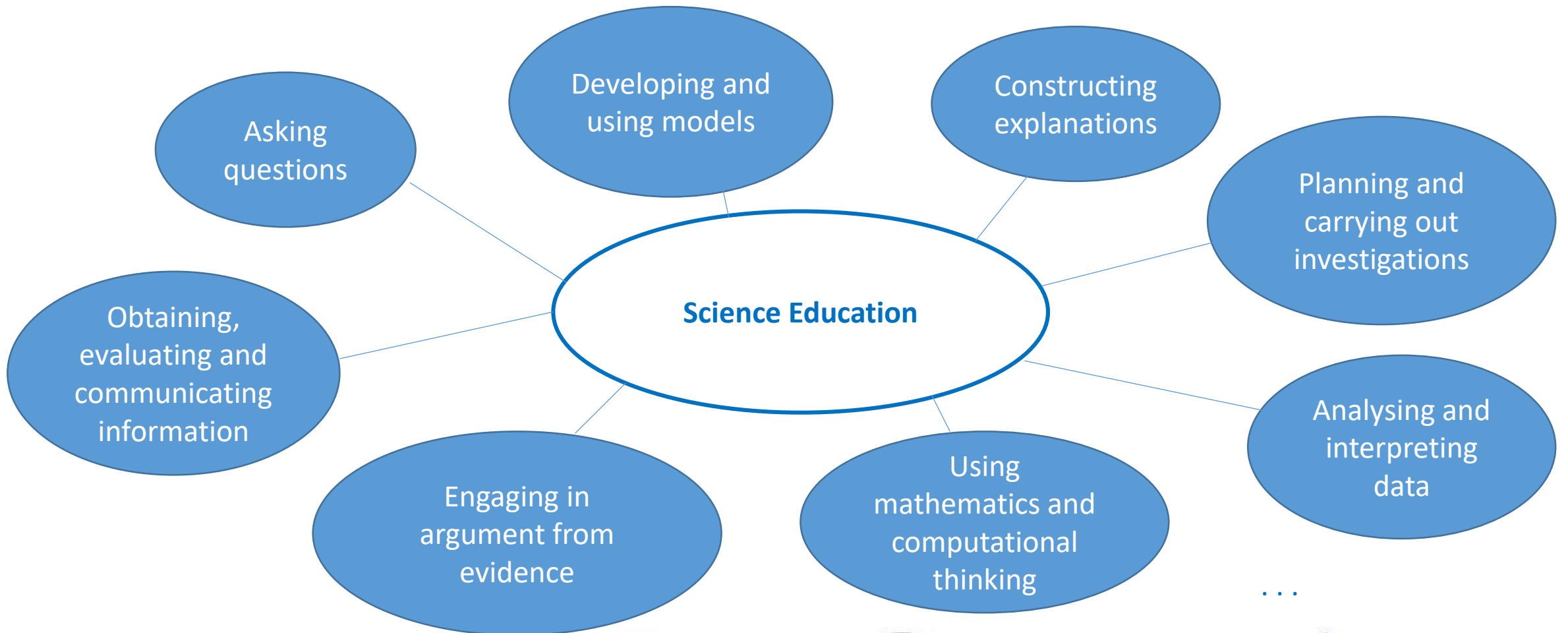

Formulation of main ideas:

Why teach science at all? What science should we teach?

Accordingly, there are some important features to consider regarding effective science teaching:

- **Experiences and interests of the students are focused:**

The teacher has to introduce assignments etc. that are founded by the interests of the students. Then they are engaged and motivated to answer the questions and problems they have raised through researching. Thus the teacher enables them to develop ideas and skills based on their experiences and topics.

- **Attitudes**

The interests of the students should be perceived and taken seriously. Furthermore it is important, that the teacher knows the students very well, because then he/she can take into account their stage of development, plan the lessons according to their competencies and give the right assistance (scaffolding). In addition, it is important which attitude the teacher himself or herself has to science. He must have the confidence to teach science related subjects and notice the importance of science knowledge and process skills for the overall development of the students.

Formulation of main ideas:

Why teach science at all? What science should we teach?

- **Developing a climate of learning:**

The activities happening in the classroom take place within the social climate. The teacher and the other adults have an important role helping students to create their knowledge, because they influence each other in their ability and willingness to learn. It is important that they respect each other and the different ideas and interests are valued and taken seriously. Thus a classroom climate in which the students feel safe to express their ideas could be established and lays the foundation for continued and motivated learning.

Content

1. Education leads to an understanding of the science

- Formulation of main ideas: Why teach science at all? What science should we teach?
- [Big Ideas of Science Education](#)
- Didactic procedures for the development of scientific ideas

2. Model of learning through inquiry (Wynne Harlen)

3. Science process skills

4. Activities examples

Formulation of main ideas:

What education concept meets these conditions?

A very suitable concept we can use for appropriate development of scientific literacy is the concept of **Big Ideas of Science Education** (Prof. Wynne Harlen, University Bristol), because it clearly reflects most of the actual problems of primary science education. It is aimed not only on functional development of fundamental ideas of science, but it deals also with scientific processes and the whole nature of science. The scientific content is developed together with the scientific process skills using inductive way of teaching. Overall the students obtain an appropriate idea about the nature of science.



Formulation of main ideas:

What education concept meets these conditions?

The concept identifies **14 ideas** to be developed during elementary science education: **10 fundamental Big Ideas of Science** and additional **4 Big Ideas about Science**.

The ideas are...

... so big that they explain many different phenomena.

... still so comprehensible that even elementary school students can approach them.



Big Ideas of Science Education

1. All matter in the universe is made of very small particles.
2. Objects can effect other objects at a distance.
3. Changing the movement of an object requires a net force to be acting on it.
4. The total amount of energy in the universe is always the same but can be transferred from one energy store to another during an event.
5. The composition of the earth and its atmosphere and the processes occurring within them shape the earth's surface and its climate.
6. Our solar system is a very small part of one of billions of galaxies in the universe.
7. Organisms are organized on a cellular basis and have finite life span.
8. Organisms require a supply of energy and materials for which they often depend on, or compete with, other organisms.
9. Genetic information is passed down from one generation of organisms to another.
10. The diversity of organisms, living and extinct, is the result of evolution.

Big Ideas about Science Education

1. Science is about finding the cause or cause of phenomena in the natural world.
2. Scientific explanations, theories and models are those that best fit the evidence available at a particular time.
3. The knowledge produced by science is used in engineering and technologies to create products to serve human ends.
4. Applications of science often have ethical, social, economic and political implications.

Content

1. Education leads to an understanding of the science

- Formulation of main ideas: Why teach science at all? What science should we teach?
- Big Ideas of Science Education
- *Didactic procedures for the development of scientific ideas*

2. Model of learning through inquiry (Wynne Harlen)

3. Science process skills

4. Activities examples

How to develop Big Ideas: From small to big ideas

The life of the students is full of experiences which can not be explained by their previous knowledge. Their thinking and their scientific understanding are still evolving. Typically students are keen on understanding phenomena but are not yet able to grasp all the necessary perspectives and to consider them in their deliberations or to understand different relationships and interactions between individual phenomena.

Therefore, it is necessary for students to observe and study these phenomena continuously and in-depth. Thus they are able to understand the mutual aspects of them and the small ideas (which are explaining particle phenomena) are further linked together using induction – from small the bigger ideas are created.

This bigger idea is more functional and helps to understand natural phenomena better. Therefore students should be equipped with a huge amount of small ideas, because they are essential for the creation of ideas which are more operational and general.

How to develop Big Ideas: From small to big ideas

This process in which small ideas are shifted to bigger ones could be compared to the process of solving a puzzle. The small pieces have to be observed and examined to look how they fit together. Thus with the small particular pieces (for example with the same color) a bigger one could be created which in turn is a small part of the whole picture. Therefore it is necessary to observe and compare a lot for creating the small parts of the puzzle.



Borders of the small parts indicate how they are going to be put together – if we observe them well.

So it is similar to the process using induction, because the small ideas are put together to create a complex picture of the whole phenomenon.

How to develop Big Ideas: From small to big ideas

The special thing about this concept is, that the big idea is always present. It sets the framework and the structure in which the students could move and examine the whole phenomenon. Thus it is important that the teacher always have the big idea in mind, because he or she has to guide the students if they run out of the frame but also has to encourage them to move within the framework for improving their knowledge and skills by learning through inquiry.

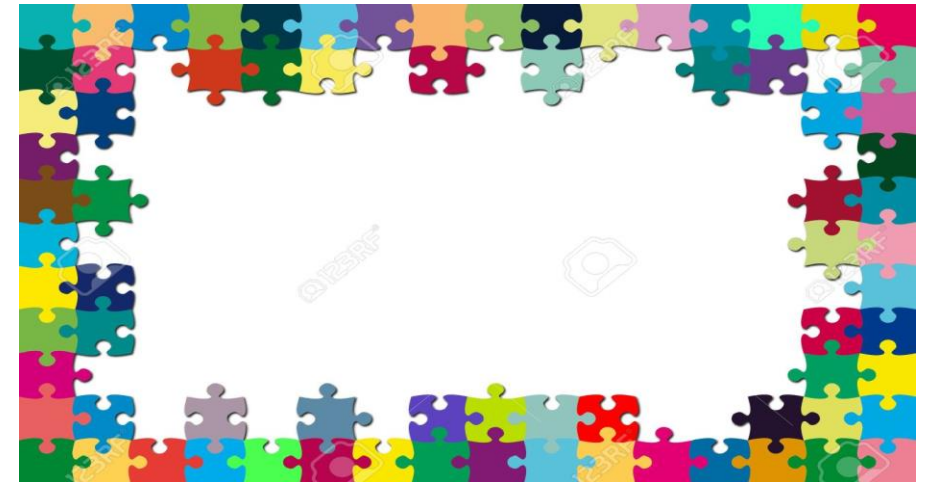

How to develop Big Ideas: from scientific content-related ideas to scientific process-related ideas

The entire process is raised by some experience the student makes in interacting with his environment, creating questions or problems which need to be answered. Thus the starting point of every activity is in proposition of an appropriate research (inquiry) question. To find an answer, these content-related questions must be transferred in process-related questions, because then the problem can be examined by learning through inquiry.

The role of the teacher is, to lead the students to find the answer, using inquiry and introduction as a part of it. All the proposed teaching instructions should lead the students to their inquiry effort. Using this approach, science process skills can be developed.

The students feel their own competence to find answers and further they are more willing to deal with more and more difficult tasks. Development of science process skills equips students with a tool for changing small ideas to bigger ones, because they are moving from description to understanding the nature.

How to develop Big Ideas: grasping nature of science using inductive way of teaching

The cognitive key tool the students use to develop their ideas of and about science can be named as scientific skill and could further described as follows: scientific capability concerned with gathering and using evidence for proving or refuting prior understanding. This complex skill can be split into specific skills and further can be better understood in connection with effort of scientific literacy development. The activities proposed in the I-S.K.Y.P.E. project are designed to highlight development of the mentioned skills.

Content

1. Education leads to an understanding of the science

- Formulation of main ideas: Why teach science at all? What science should we teach?
- Big Ideas of Science Education
- Didactic procedures for the development of scientific ideas

2. Model of learning through inquiry (Wynne Harlen)

3. Science process skills

4. Activities examples

Model of learning through inquiry

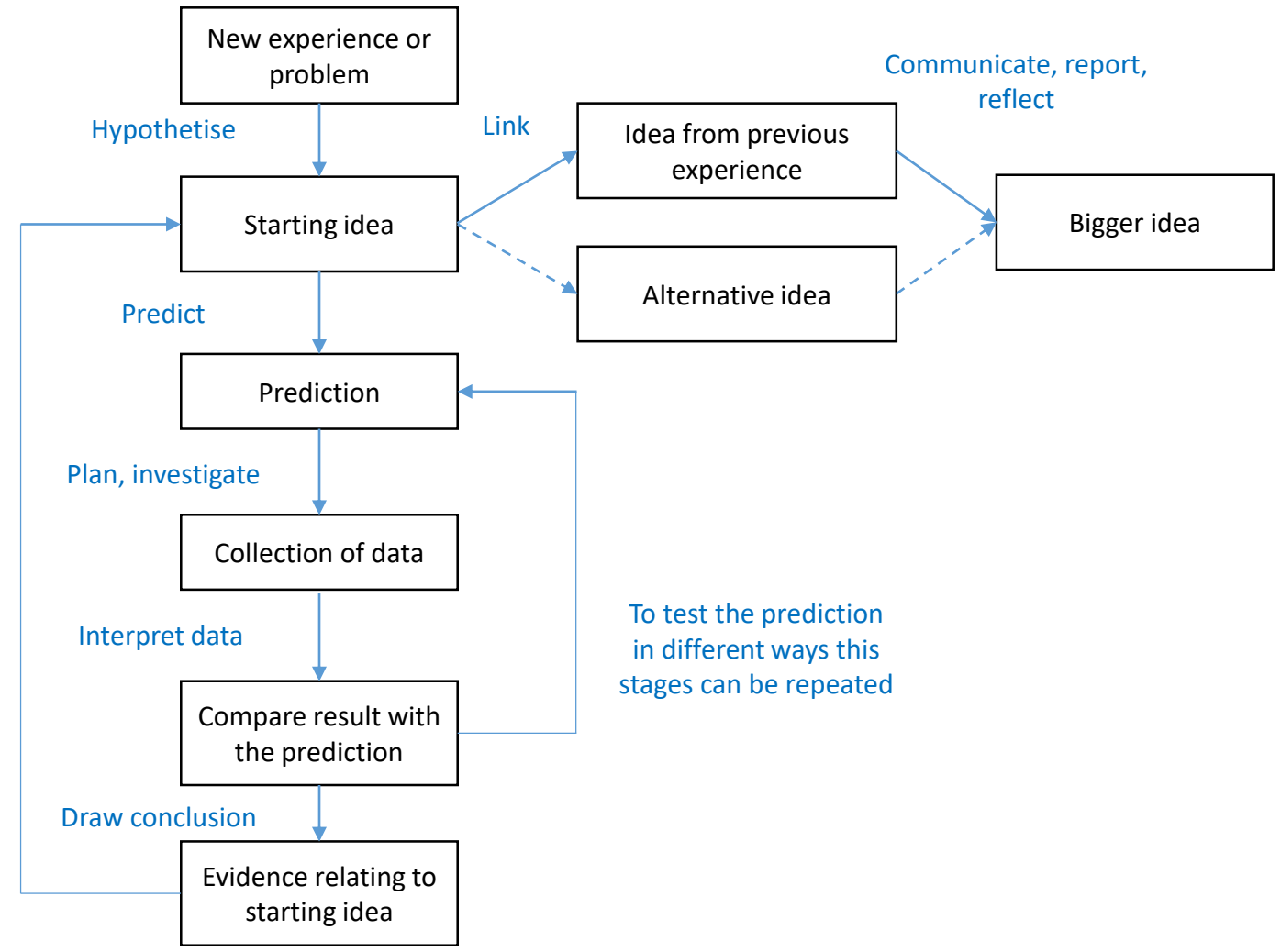

Model of learning through inquiry: Basic information

The theoretical basis of the concept of the big ideas is, that the students should learn through inquiry. That means they shouldn't only create knowledge by memorizing facts and by mere describing what they see. They should understand the underlying mechanisms also. The aim is that students understand why objects have certain characteristics and show certain behaviors (e.g. float or fly).

To find out about the „why“, the underlying mechanisms, students need several (science process) skills, like hypothesizing, planning, observing, which organize the process of learning through inquiry. The term inquiry itself refers to seeking information to answer questions which is the general part of scientific research. Thus scientific inquiry applies to questions of the (natural and made) world around us and leads to the understanding of scientific phenomena.

The model of learning through inquiry pictured the individual steps of a scientific research process. It can be adapted to the level of development of the students, so you don't have to start from the beginning but could start at the point in the research process where the students are currently standing.

Model of learning through inquiry: Basic information

“Developing scientific inquiry skills is central to the construction of ideas that enable understanding. This is an important reason for helping students develop their inquiry skills and use them with appropriate rigor. Another reason, of course, is that by reflecting on their learning they develop skills needed for making sense of new experiences throughout their lives.” (Harlen, 2015)

To illustrate the process of scientific research, the individual steps of the model of learning through inquiry are described subsequent.

Model of learning through inquiry: Phase



The process starts with a new experience or a problem that raises a question, because it couldn't be explained with the current knowledge of the students. Thus the experience or the problem has to be compared with the own experiences to identify investigable questions and hypotheses. Hence a starting idea, which forms the basis of the scientific research process, has been created.

Model of learning through inquiry: Phase

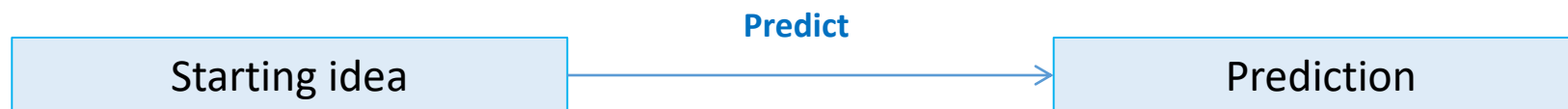

Within the starting idea there are several hypotheses to be tested. One of these has to be examined in more detail. So the students have to make a prediction based on this existing idea, which could be inquired through inductive learning.

Model of learning through inquiry: Phase

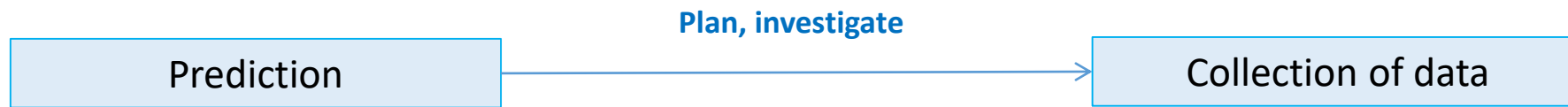

In the next step an investigation is conducted to see whether there is evidence to support the prediction. Therefore the students have to plan exactly which research activities are carried out to gather appropriate information and collect data. This process has to be adapted to their scientific process skills and their scientific knowledge. It is the responsibility of the teacher to encourage students to reflect on the links between the respective results and give them sufficient time to investigate the prediction. That enables the students not only to generate more scientific knowledge, but also to enhance their scientific process skills.

Model of learning through inquiry: Phase



It is quite often, that scientific education is finished with the collection of data. But it is necessary that the students compare the collected data and the results with the predictions they have made. Then they will find out, if the results can explain the prediction or if they have to repeat the process and test the prediction in different ways.

Model of learning through inquiry: Phase



If the prediction was suitable, the conclusions from the tests are used for evidence relating to the starting idea. The students have to find out whether or not the starting idea provides a good explanation of the new experience or if it could be a solution to the initial problem. In this stage it can be emphasized that the students learn/are able to argue for their conclusion using evidence.

Model of learning through inquiry: Phase

If the evidence shows that the starting idea gives a good explanation, it can be linked with the previous experience. Therefore it is helpful, when the students communicate and report their research process. Then they are able to take a different perspective, reflect the process and relate it to the previous knowledge, so that it can be extended. So a small idea or a specific problem becomes a “bigger” (but not confirmed) idea by learning through inquiry. This bigger idea relates to several situations and could be generalized to a set of phenomena. If the starting idea hasn’t provided appropriate explanations an alternative idea must be found and investigated.

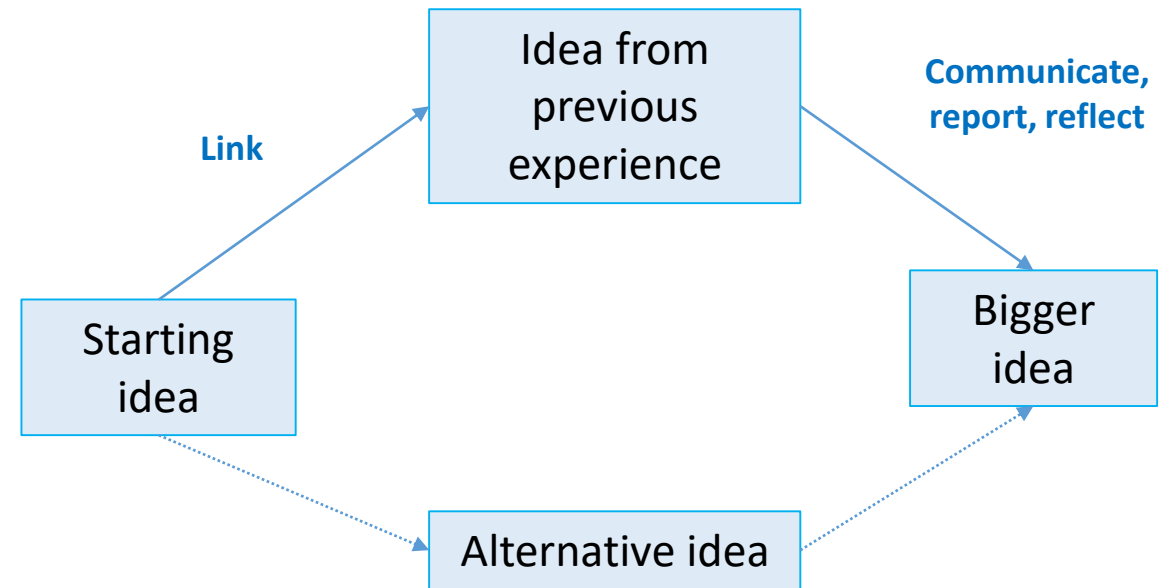

Content

1. Education leads to an understanding of the science

- Formulation of main ideas: Why teach science at all? What science should we teach?
- Big Ideas of Science Education
- Didactic procedures for the development of scientific ideas

2. Model of learning through inquiry (Wynne Harlen)

3. Science process skills

4. Activities examples

Science Process Skills

During the described process of research-based learning, not only knowledge is generated, but also many scientific process capabilities are claimed, practiced and further developed. These skills are clarified in the following slides.

It is not only important to know, that these skills are promoted by learning through inquiry, but it is also important how the teacher can encourage the students, give hints and guide by asking the right questions.

In doing so, the teacher can use several questions which are adapted to the state of development of the students and the research process. These questions enable students to verbalize their thinking and ideas, encouraging the use of research skills, strengthening collaboration and interaction, and helping students to reflect their actions.

Appropriate questions regarding the respective activity or to encourage the specific capabilities can be found below in the blue boxes.

Science Process Skills: Raising questions and planning inquiries

At the beginning of the research it is important to activate the children's prior knowledge and to let them develop their ideas. In this way, the interests and experiences of the students are focused and taken up again within the process so that the students can identify themselves with the prior question. Thus it is important that the students find hypotheses and make initial predictions which can be investigated. This investigation has to be planned. The role of the teacher is to encourage and support the students according to their interests and stage of development.

Teachers' questions to encourage student's questioning and planning:

- What would you like to know about...?
- What do you think will happen if your idea is correct?
- What do you think will happen if ... or when ...?
- What do you think will make this go ...?
- What will you need to do to find out ...?
- How will you make it fair?

Science Process Skills: Gathering information

There are many ways to gather information or to collect data. In primary school observation is most popular. In doing so, processes such as observing details, finding similarities and differences or patterns and relationships are promoted. The role of the teacher is to give the students the opportunity to observe and to encourage and support them according to their needs. The students can be given the opportunity to work with instruments such as a microscope or to use pictures and models. Furthermore all sorts of tables, diagrams, graphs, charts, figures e.g. are suitable for the observation. Besides additional sources, for example a computer, help the students to gather information. In summary, these aspects enable the students to observe detailed and targeted. That is important, because only in this way reliable data can be collected to show if the ideas and predictions are correct and deliver results that can amplify existing knowledge.

Teachers' questions to encourage skills for gathering information by observing:

What do you notice that is the same about these ...?

What differences do you notice between the ... of the same kind?

What differences do you see when you look through the lens?

How much longer (heavier, etc.) is this than ...?

What did you notice about places where you found the most ...?

What more can you find out about ... from the books and the internet?

Science Process Skills: Analyzing, interpreting and explaining

An important part of the scientific research process is to give students the opportunity to use the results of their research to enhance their understanding of scientific phenomena. Therefore it is not only necessary to observe a transformation, but also to find explanations why this arises. For this reason, it is important to look at the predictions taken from different perspectives and to examine them in many ways in order to grasp the phenomenon as comprehensively as possible and to compare the results with the starting idea. The role of the teacher is not to give the students complete answers, but instead to encourage them to test their predictions many times and connect their observations with their prior knowledge. In summary, these process skills enable the students to analyze the results precisely and to discover more and more facets (and their interactions) of the phenomenon.

Teachers' questions to support analysis and interpretation:

How did what you found out compare with what you expected?

Did you find any connection between ... and ...?

What did you find makes a difference to how fast ... how far ... how many ...?

What do you think is the reason for ...?

What would you expect if ... ?

Would ... or ... explain better, what you found?

Science Process Skills: Communicating, arguing and reflecting

These skills enable students to make their thinking "visible" to themselves and others. By exchanging information with or present results to their classmates the observations and the whole research process is reflected. During the communication with others, students are challenged to verbalized their thinking and to take a different perspective. Thus they revisit their findings from this perspective. Therefore on the one hand information is passed on, but on the other hand new ideas and questions are generated, explanations are found together, (new) knowledge is built up (because you get to know a different perspective from your own) and the own view is considered critically. The role of the teacher is to encourage students to verbalize their thinking, to communicate with each other and to provide them with appropriate materials to present their findings to the others.

Teachers' questions to support communication skills:

Can you explain that a little more?

How are you going to keep a record of what you do and find?

What kind of chart/graph/drawing do you think is the best way to show the results?

How can you explain to the others what you did and what happened?

How can you show that (what evidence do you have that) your conclusion is right?

What other conclusions can you draw from your results?

Content

1. Education leads to an understanding of the science

- Formulation of main ideas: Why teach science at all? What science should we teach?
- Big Ideas of Science Education
- Didactic procedures for the development of scientific ideas

2. Model of learning through inquiry (Wynne Harlen)

3. Science process skills

4. Activities examples

Examples of activities

Activities proposed in the project are aimed at various aspects of content, process and whole nature of science development. Using the activities, we are trying to develop:

- targeted and detailed scientific observation;
- scientific measuring as a tool for gathering reliable evidence;
- making scientific predictions that connects actual evidence with prior knowledge;
- scientific categorization which leads to systematization of prior knowledge;
- proposing own inquiry procedure leading to support of responsibility and competency;
- sensitiveness to information sources credibility;
- interfering and work with systematized data;
- scientific accuracy and scepticism.



Sundials



Erasmus+



RAABE

Spoločne ku kvalitnému vzdelávaniu

Measure local true solar time

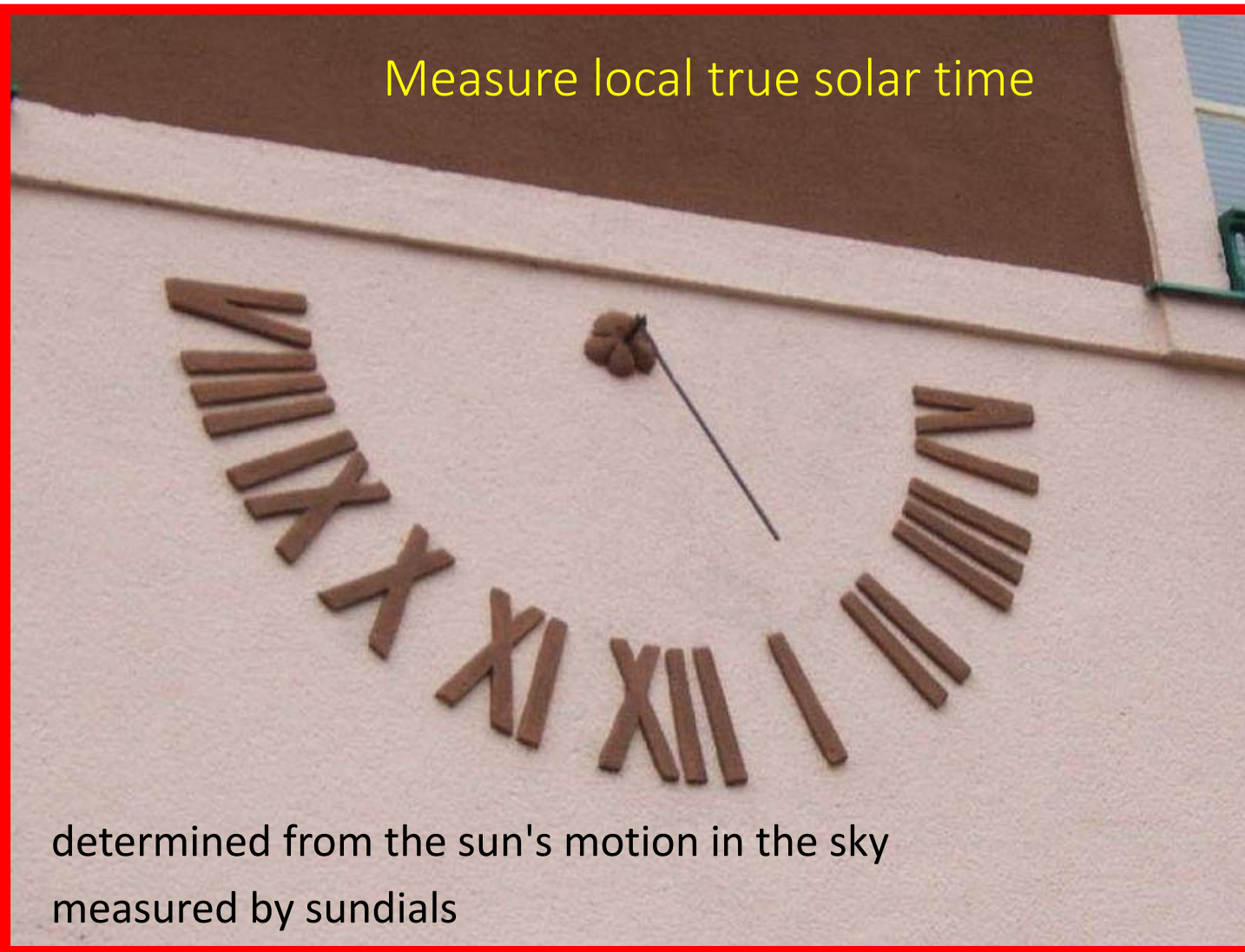

determined from the sun's motion in the sky
measured by sundials



ZÁPADOČESKÁ
UNIVERZITA
V PLZNI



ZÁKLADNÍ ŠKOLA
J. GUTHA - JARKOVSKÉHO



LOUISENLUND
LERNEN LEISTEN LEBEN



DIGITAL
CREATIVE



Erasmus+

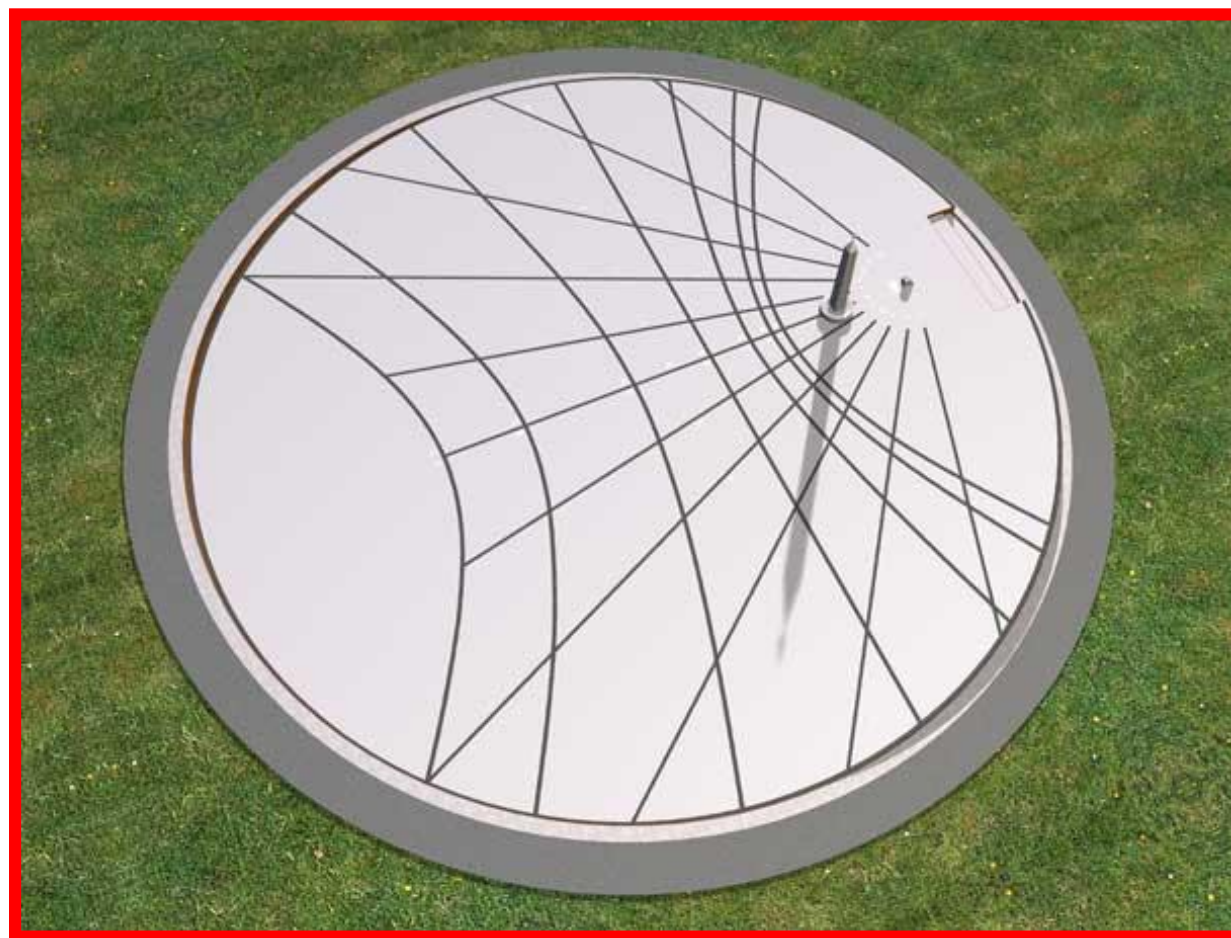

gnomon – the pointer is perpendicular to the dial



ZÁPADOČESKÁ
UNIVERZITA
V PLZNI



ZÁKLADNÍ ŠKOLA
J. GUTHA - JARKOVSKÉHO



LOUISEN LUND
LERNEN LEISTEN LEBEN



DIGITAL
CREATIVE



Erasmus+

Interactive Science
for Kids and Youngsters
i SKYPE

RAABE
Spoločne ku kvalitnému
vzdelávaniu



- style – the pointer in the direction of the Earth's axis,
- oblique to the dial
- node – ball on the top allowing to determine the period of the year



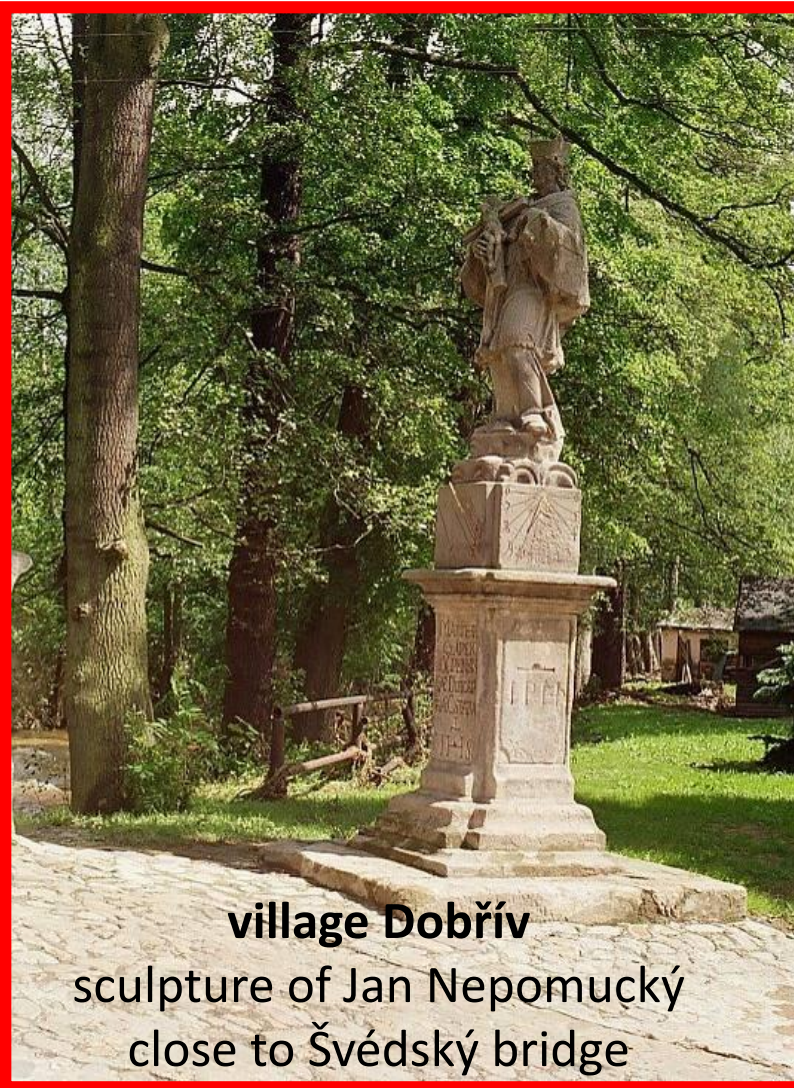

„southern“ sundial

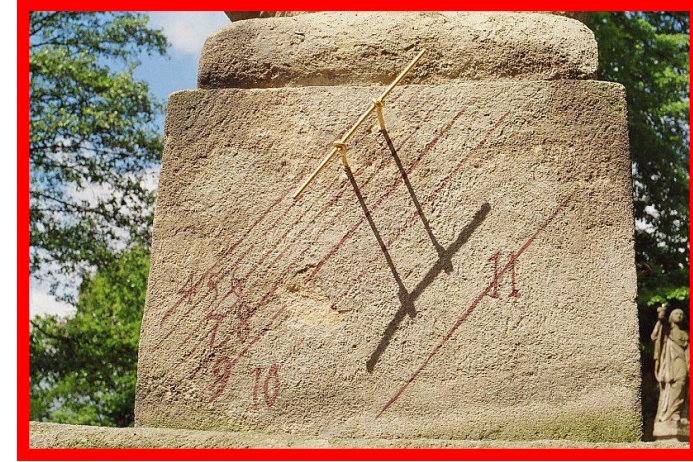

„eastern“ sundial



„western“ sundial

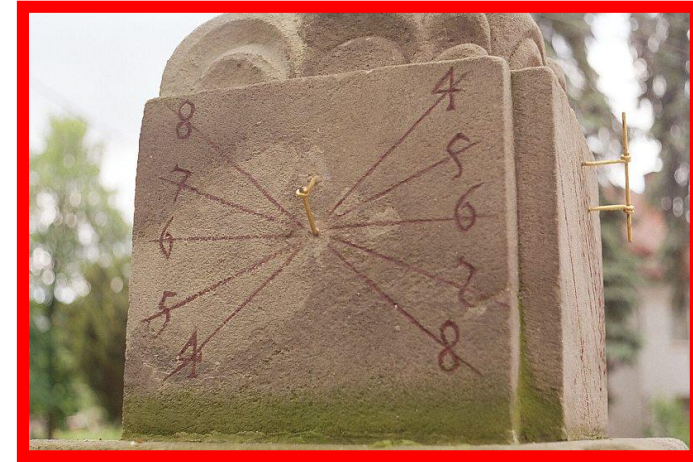

„northern“ sundial

village Dobřív
sculpture of Jan Nepomucký
close to Švédský bridge

Úloha 1b: Slnečné hodiny ve třídě

Návod na konstrukci gnómonických slunečních hodin ve třídě

1. Upravte velikost čtvrtky, aby se celá vešla na destičku z korku či polystyrénu.
2. Na čtvrtku narýsujte podél celé delší strany ve vzdálenosti 1–2 cm od okraje úsečku a vyznačte její střed.
3. Ve vyznačeném středu úsečky narýsujte kolmicí k úsečce.
4. Narýsujte půlkružnici se středem ve středu úsečky a co největším poloměrem, dosahujícím cca 1–2 cm od nejbližšího okraje a čtvrtku položte na destičku (viz obr. 1).
5. Připevněte čtvrtku ke korku v rozích ozdobnými špendlíky (s velkou hlavičkou).
6. Ve správném směru od gnómonu vyznačte na půlkružnici bod označující 12 h.
5. Obdobně vyznačte body 6 h a 18 h (viz obr. 2).

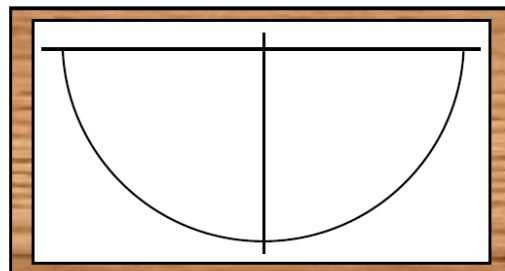

Obr. 1

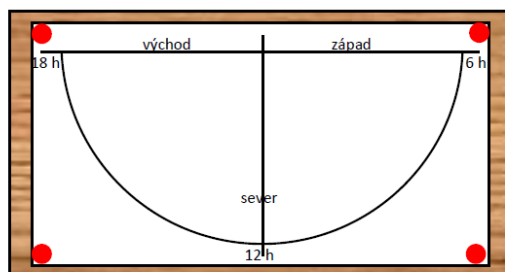

Obr. 2

production of sundials, see Methodical material

6. Do vyznačených bodů zapíchněte špendlíky a doplňte číselné označení.
7. Vyznačte další body na stupnici (buď pomocí provázku stejné délky jako poloměr kružnice navázaného na body 6 h, 12 h, 18 h s využitím vlastností rovnostranného trojúhelníku – viz obr. 2 a 3 v předchozí úloze – a následně rozdělení vzdáleností mezi získanými body na poloviny, nebo rozdělením na patřičný počet stejně dlouhých úseků metodou pokus–omyl). Vzniklé body označte barevnými špendlíky a doplňte číselné hodnoty.
8. Do průsečíku přímek zapíchněte špejli.
9. Pomocí kompasu, buzoly či mobilu nastavte sluneční hodiny do správné polohy.
 - a) Kedy nie je možné použiť slnečné hodiny?
 - b) Jak musíme upravit sluneční hodiny vytvořené v létě, aby ukazovaly správný čas i v zimě?
 - c) Jak môžeme slnečné hodiny použiť v noci?
 - d) Jak se změní stín vržený gnómonem v zimě a v létě?

Cardinal direction

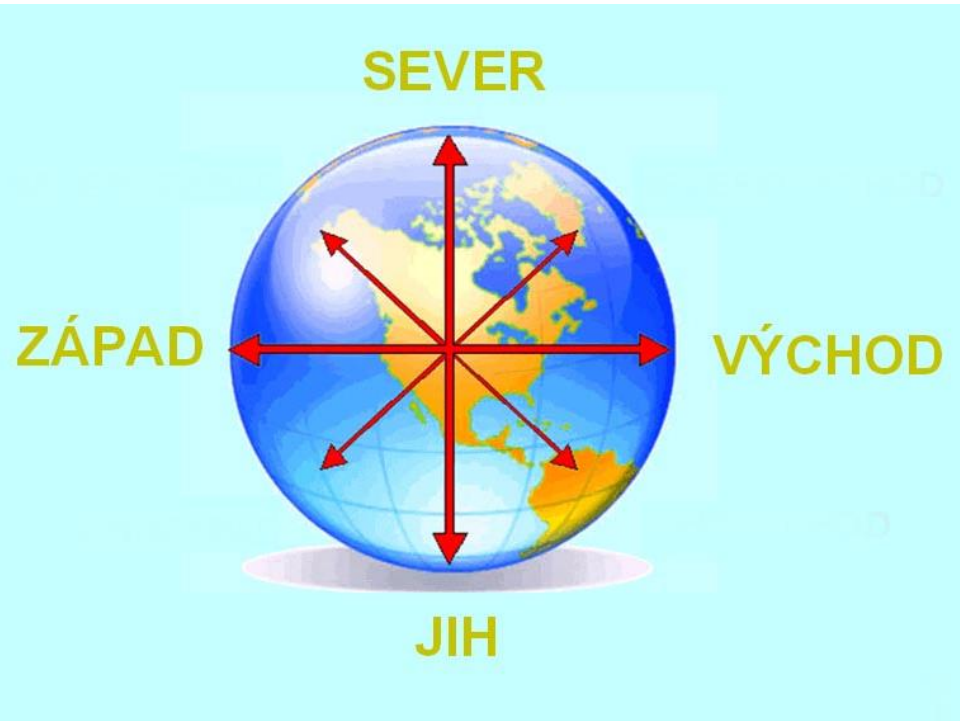

NEWS



meridian

same distance, from pole to pole 20.000 km

15° = 1 hod ... timezone

circle of latitude

different distance,
from 40.000 km (equator) to zero (pole)

Tropical circle

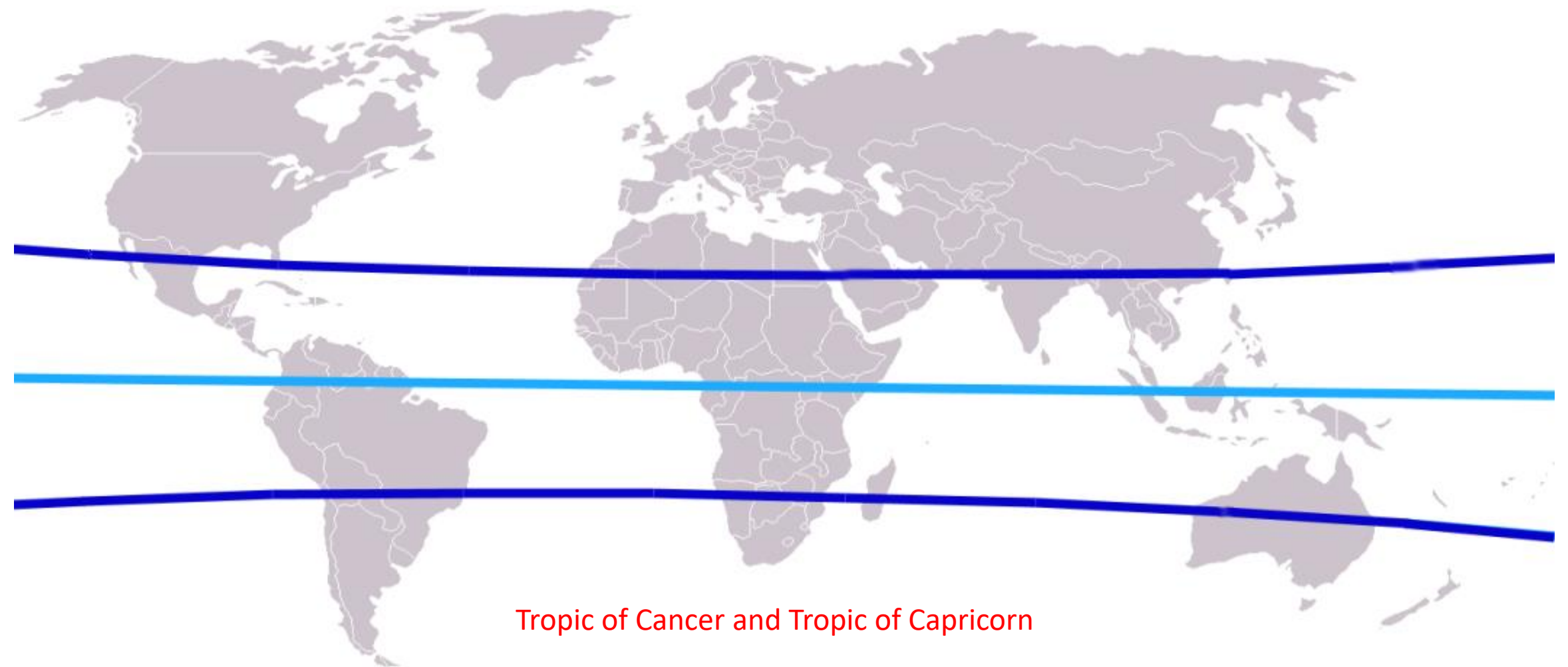

Tropic of Cancer and Tropic of Capricorn

Circle of latitude

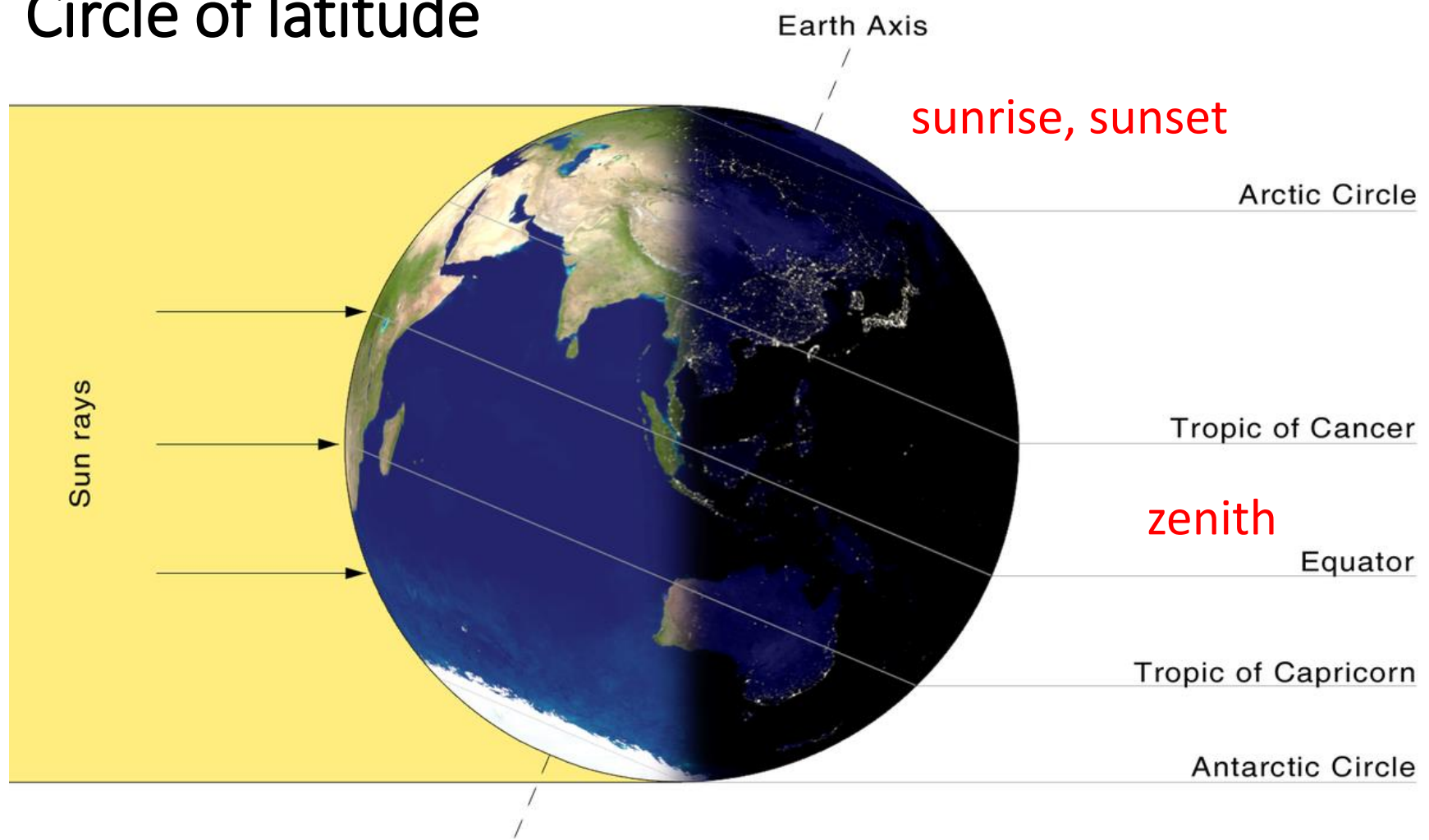

Orientation in nature



approximate orientation

map, compass



Sun

morning East noon South evening West

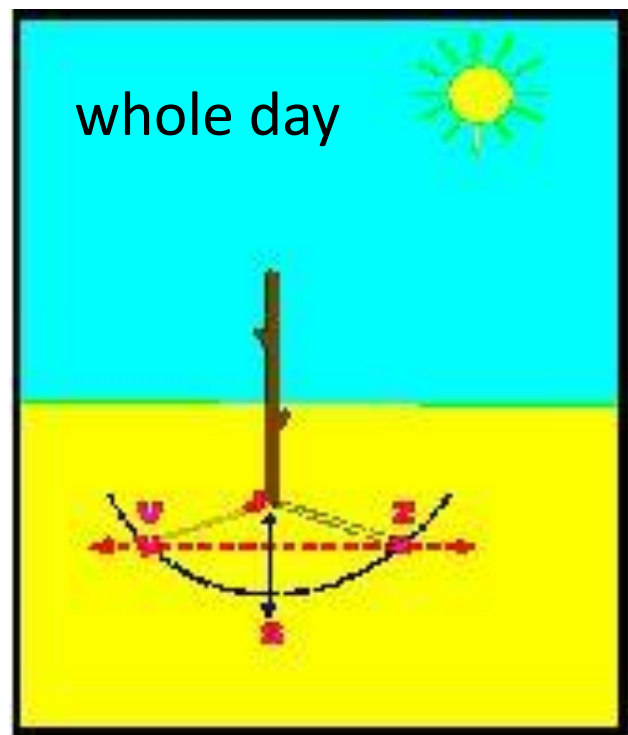
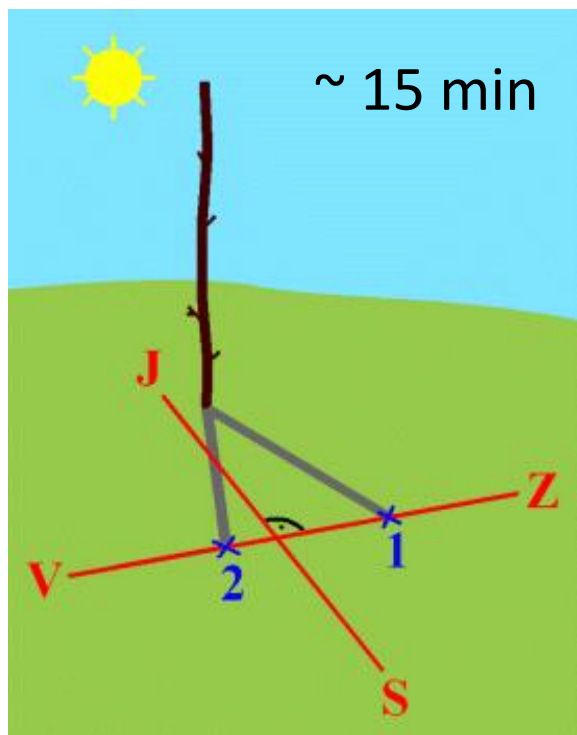

solar noon vs. noon



Stars

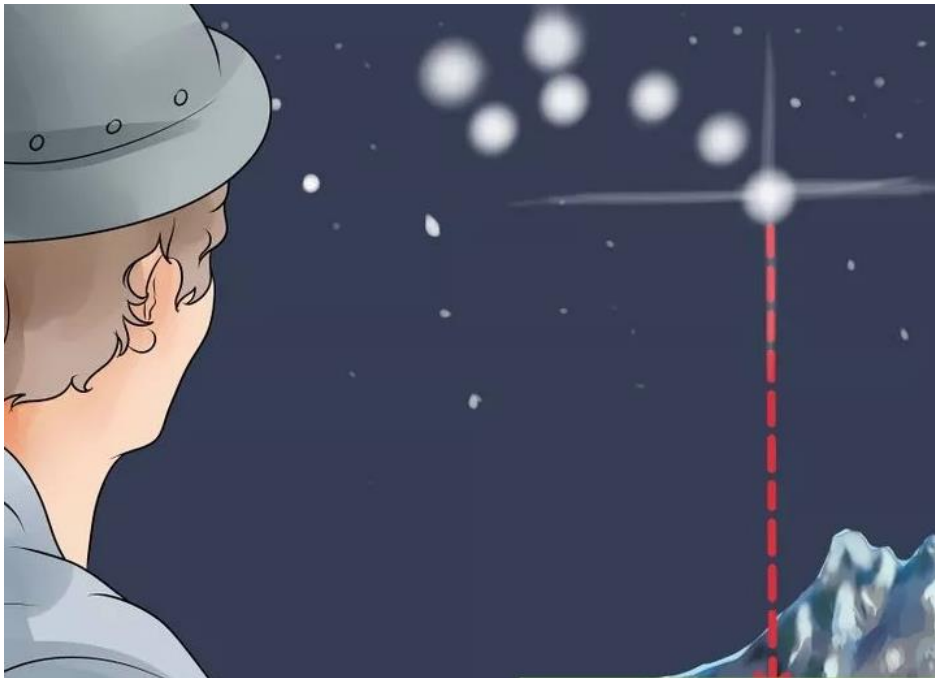

north hemisphere

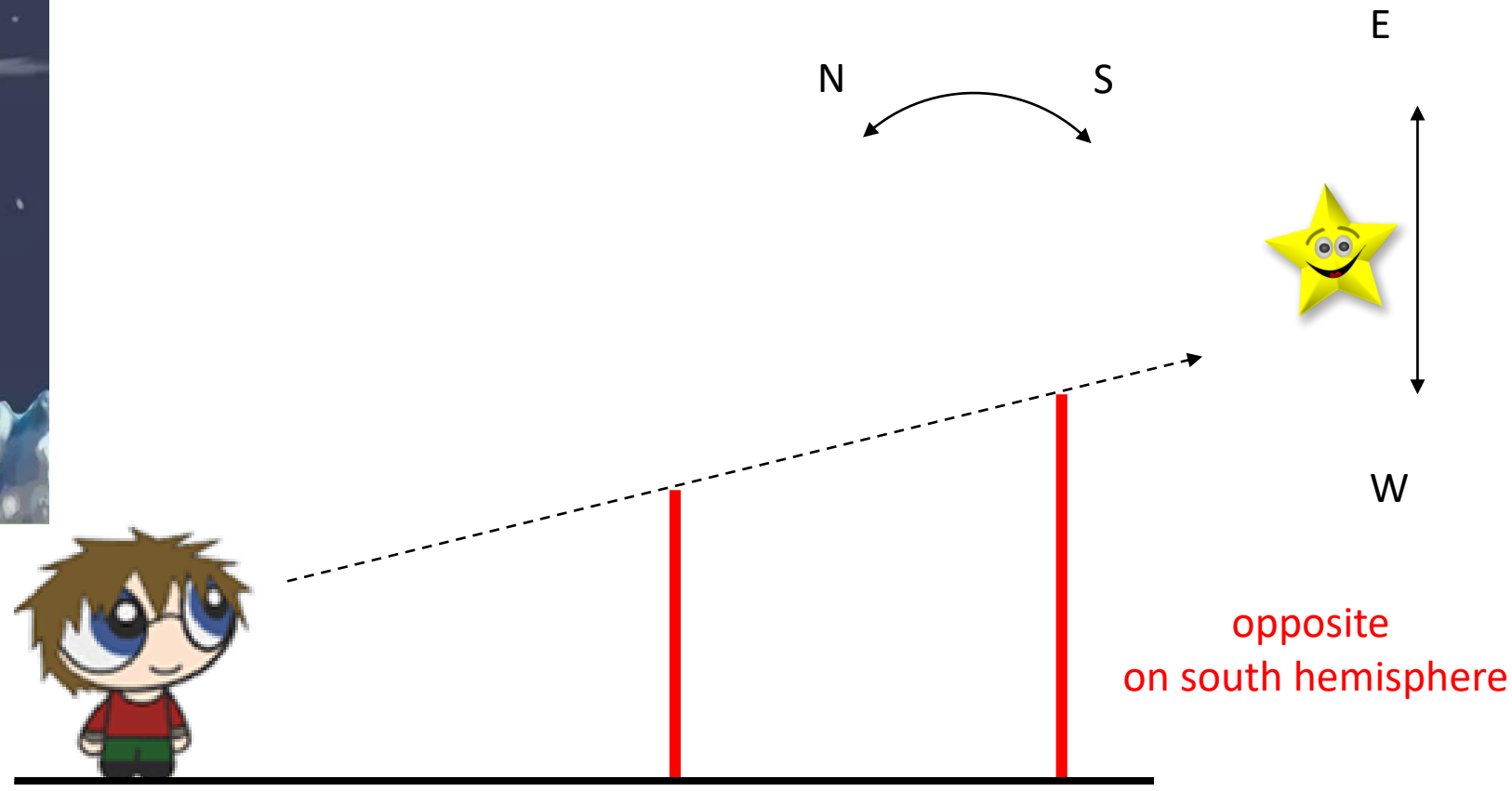

Moon

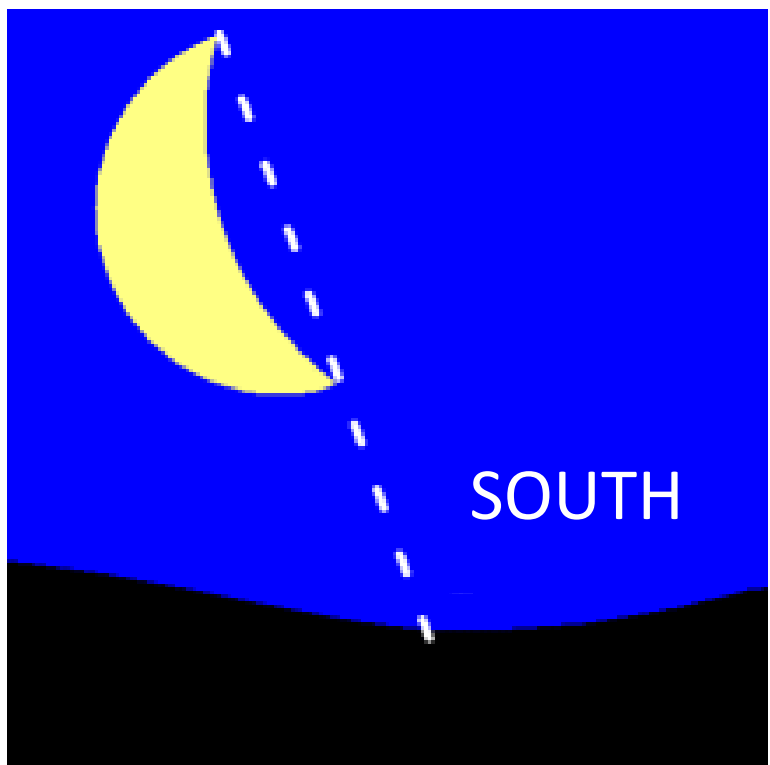

north hemisphere



Erasmus+



Constellations

- Who know some constellations?
- Which one?
- How many constellations do we know?
- What is on picture?
 - Big dipper
 - Ursa Minor
 - Ursa Major



**Pay attention!
Constellation is
not just the
groups of bright
stars.**



ZÁPADOČESKÁ
UNIVERZITA
V PLZNI



ZÁKLADNÍ ŠKOLA
J. GUTHA - JARKOVSKÉHO



LOUISENLUND
LERNEN LEISTEN LEBEN



ZÁKLADNÁ ŠKOLA
S MATERSKOU ŠKOLOU
KRÁĽA SVÄTOPLUKA
SINTAVA



DIGITAL
CREATIVE

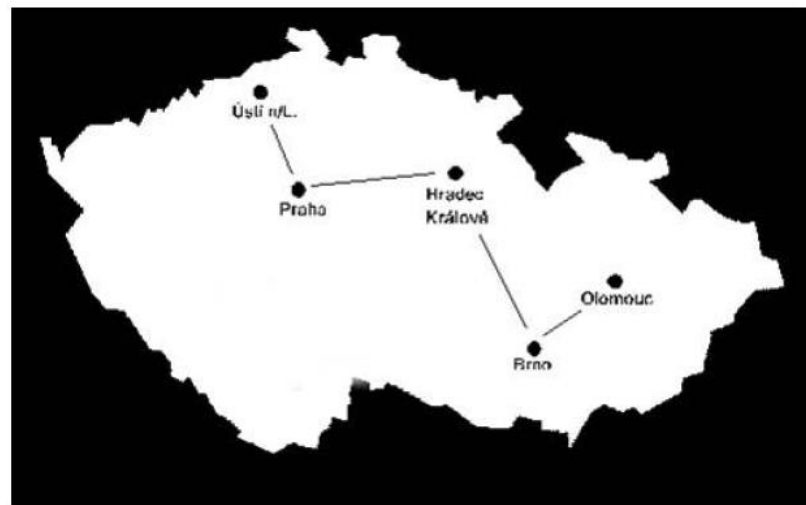
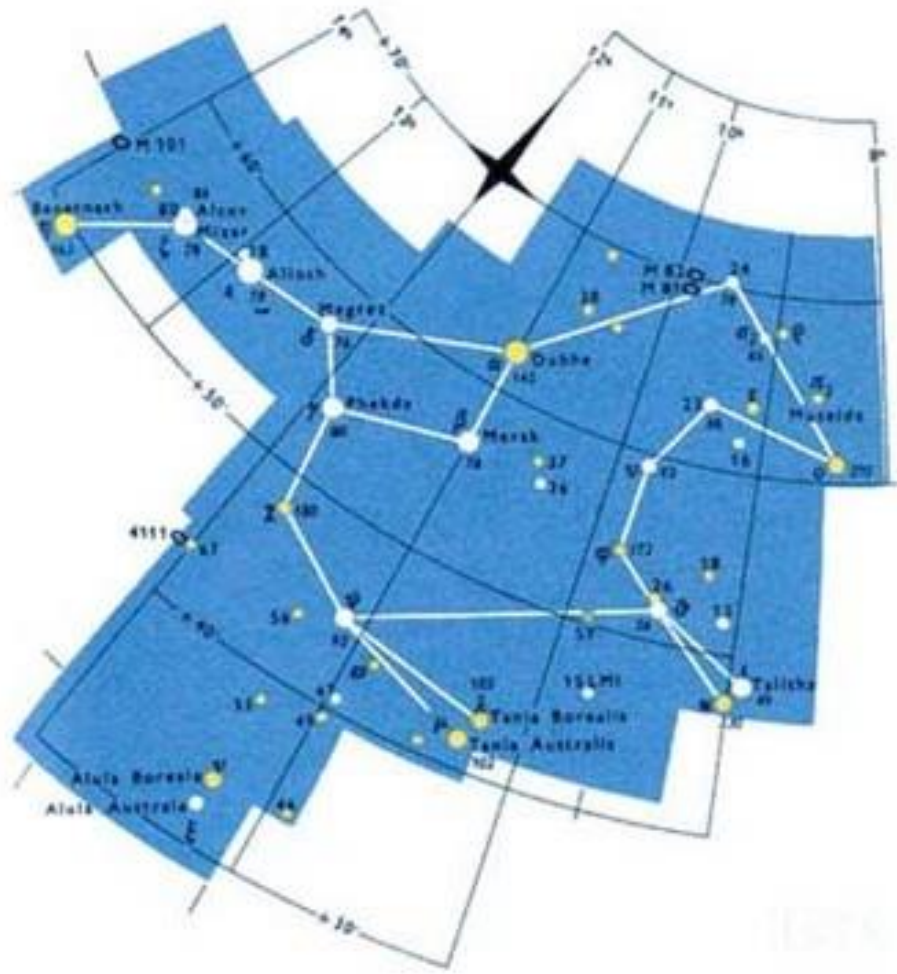
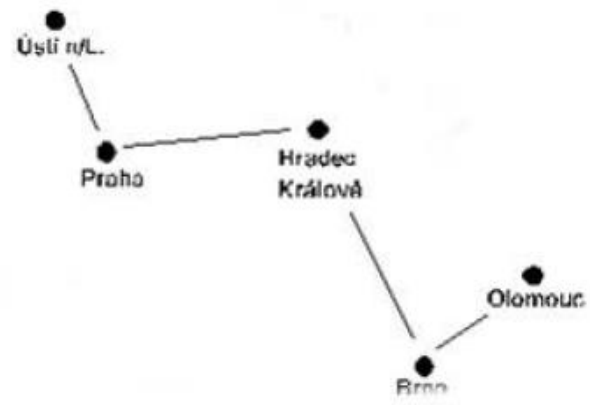

Painting of Constellations



- Bear
- Swan
- Eagle
- Dolphin



Model of Constellations

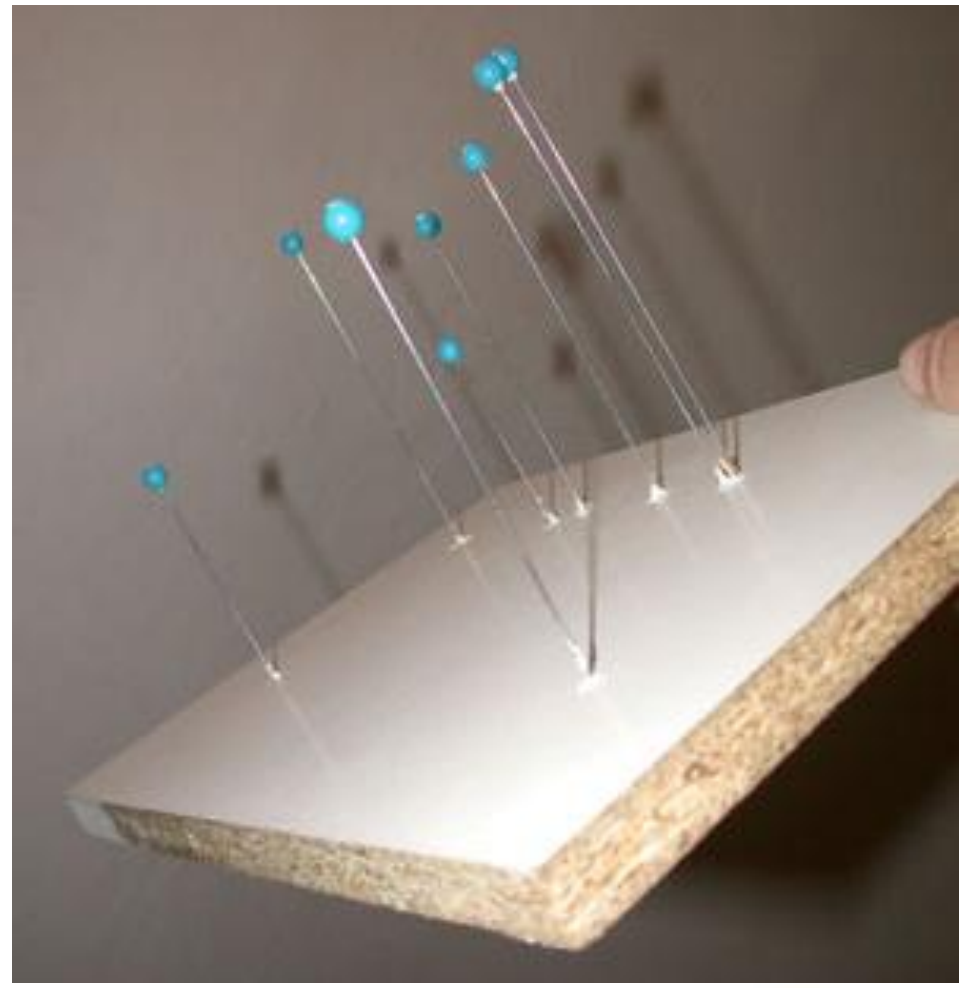

Polystyrene

Wooden sticks

Coloured
small balls

Rope

„Big dipper“
Orion
Kassiopeia

Brightness of stars – night sky

image

Stellarium

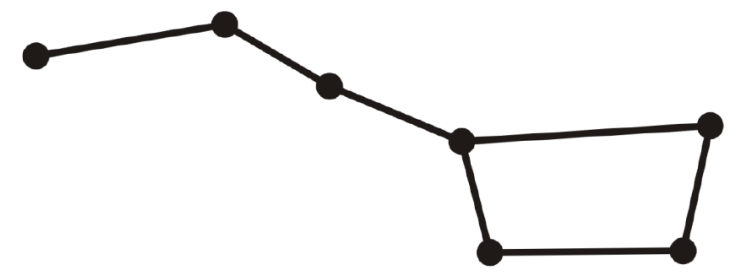
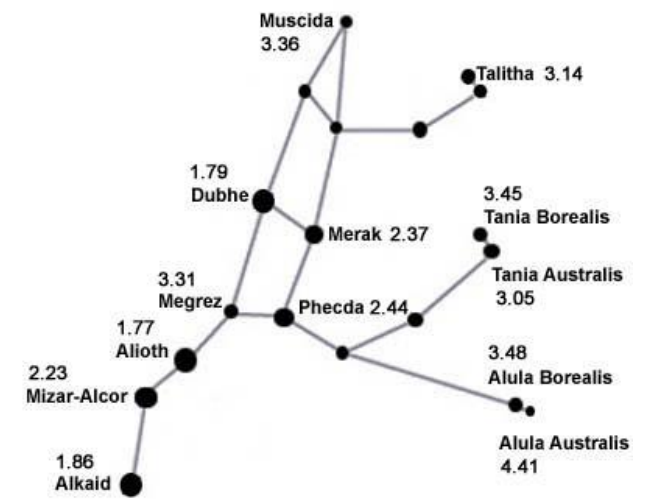

Project: I – S.K.Y.P.E. (Interactive Science for Kids and Youngsters in Primary Education)

This project has been funded with the support of the Erasmus+ Programme, K2 Action, Strategic Partnerships in School Education.

Project Agreement Number: 2016-1-SK01-KA201-022549

Conclusion:

The process used for building up scientific ideas is the same important as the obtained knowledge itself. Pupils should be able to continuously work with their understandings of the world and they should understand the significance of science in society.

The current publication reflects only the author's view and neither the Slovak National Agency, nor the European Commission are responsible for any use that may be made of the information it contains.

Project: I – S.K.Y.P.E. (Interactive Science for Kids and Youngsters in Primary Education)

This project has been funded with the support of the Erasmus+ Programme, K2 Action, Strategic Partnerships in School Education.

Project Agreement Number: 2016-1-SK01-KA201-022549

References:

HARLEN, W. (ed.) 2010. *Principles and big ideas of science education*. Herts : Association for Science Education. ISBN: 978086357 4 313. [online]. [cit. 2016-07-07].

Available online: www.ase.org.uk

HARLEN, W. (ed.) 2015. *Working with Big Ideas of Science Education*. Science Education Programme of IAP : Trieste. ISBN: 9788894078404. [online]. [cit. 2016-07-07]. Available online :

<http://www.interacademies.net/>

The current publication reflects only the author's view and neither the Slovak National Agency, nor the European Commission are responsible for any use that may be made of the information it contains.